

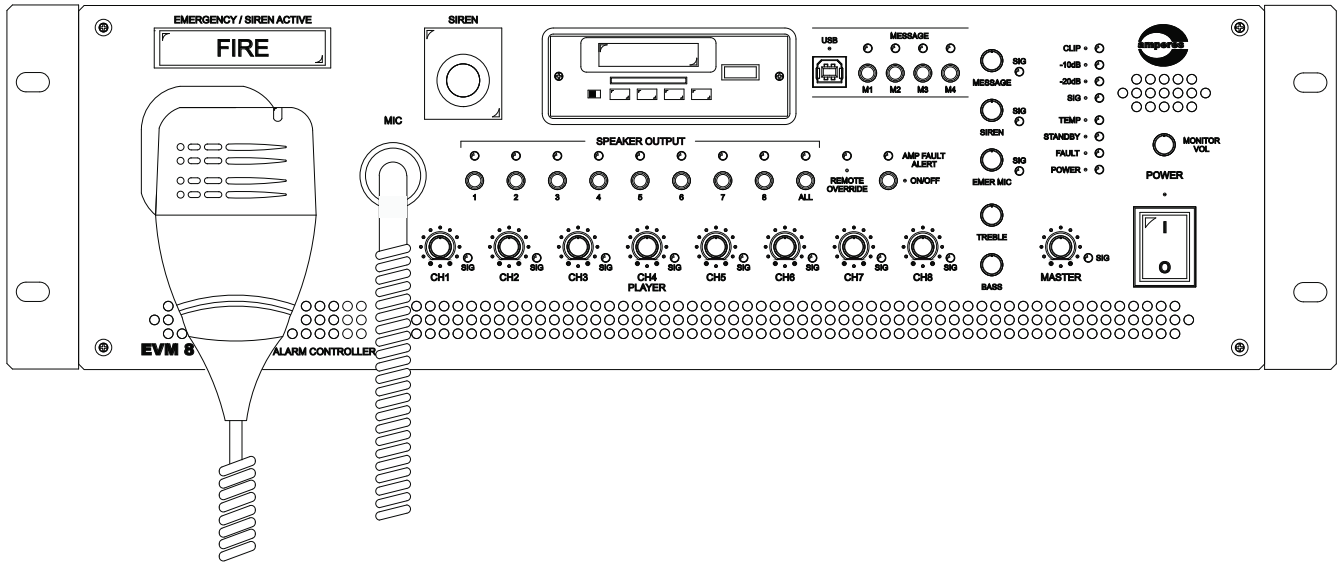

INSTRUCTION MANUAL

EVM8810

Voice Alarm Controller (Master)



Thank you for choosing another quality product from Amperes Electronics.

Product in Summary

EVM8810 provides a cost efficient way for powering up the BGM / Paging system with voice evacuation features to your premises. It is a compact voice alarm controller with necessary elements to comply to authority's requirement for a complete EVAC system, such as emergency microphone, siren tone generator and voice message which can be triggered manually or automatically by interfacing with FI6000.

It also includes a preamplifier mixer with individual tone controls which allows connections to external BGM players or microphone inputs. Media player with USB, SD Card, FM tuner and Bluetooth player that comes with the device eliminates the need of external music player. EVM8810 comes with highly efficient 1000W 100V amplifier module with fault sensor. The master unit has 8 zone outputs, and when required for expansion, EVS8820 can be linked to form a bigger system with bigger power output.

EVM8810 or EVS8820 shall be the right choice for compact system in complex installation for EVAC system in your premises.



Ver 1 / Updated May 24

In our support towards environment, we shall no longer print manuals to be accompanied with each product. Please view through browser and print them only when necessary.



Parts Identification

Front View

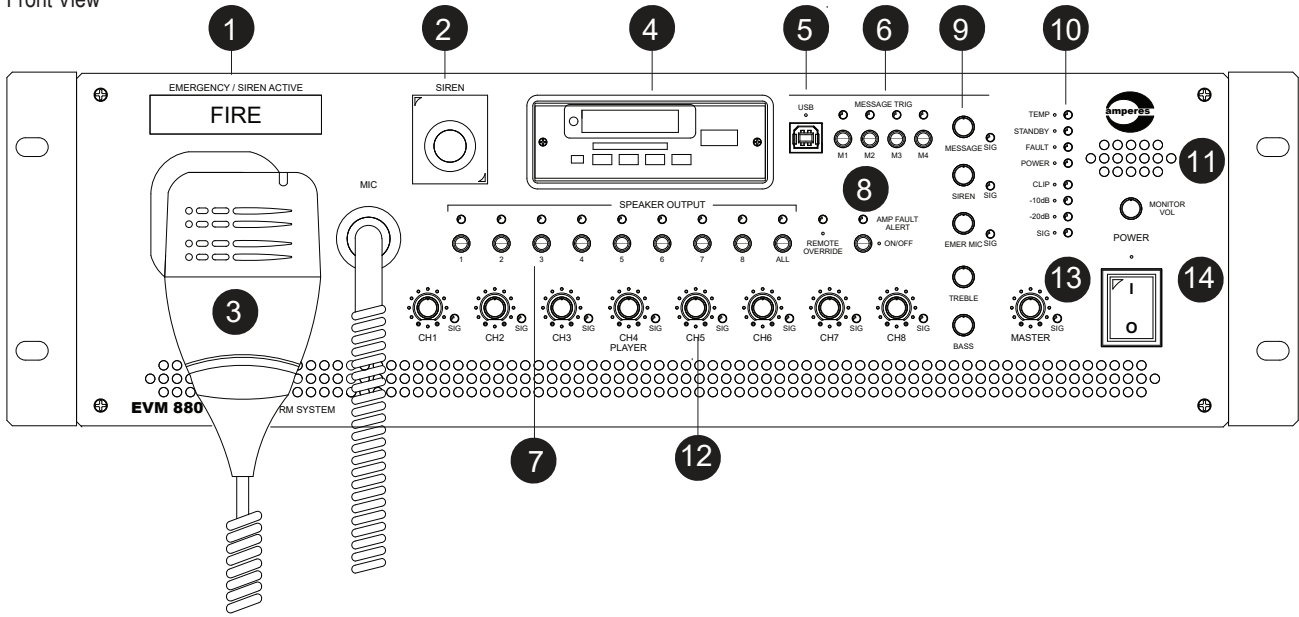

Rear View

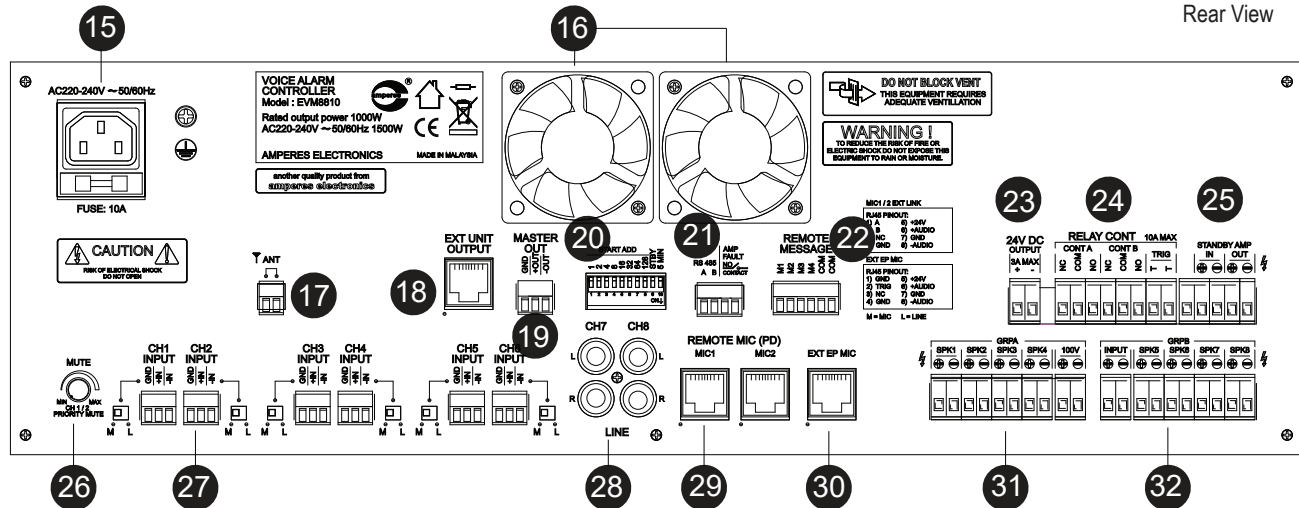

1. FIRE INDICATOR

The indicator shall lit with flashing when the handheld emergency mic is in use or when the siren is triggered. Siren triggered from the rear / remote port will also lit the Fire window.

2. SIREN PUSH BUTTON

To trigger the siren (continuous tone), lift the caps and press the button momentarily. To off the siren, press the button again.

3. HANDHELD EMERGENCY MICROPHONE

To broadcast, lift the microphone and press the side switch of the mic, this will activate all zones, bypassing any ongoing BGM being played or any incoming paging / messages. It has the highest priority of all audio inputs.

4. MEDIA PLAYER

The built in player includes FM tuner, USB, SD card and Bluetooth. Access to the controls can be done at the player module or via IR remote controller.

5. SERIAL PORT FOR MESSAGE PROGRAMMING

This is to connect to your PC to upload message to the device. Please refer to section "Uploading Messages".

6. MESSAGE PLAYBACK BUTTON

The front buttons are for manually triggering message stored in the device. Any message triggered either by the front or rear shall bypass any BGM being played, but in turn, will be overridden by the EXT EP or when the handheld PTT mic is activated.

Technical Specifications

7. SPEAKER OUTPUT ZONE SELECTION

The 8 channel speaker line selector is available for selecting BGM zones. In case of remote paging microphone connected to the device is active, it shall override the selected zones. Remote Override LED shall lit when this event occurs.

8. AMP FAULT ALERT

EVM8810 is equipped with amplifier fault sensor, which any fault to the amplifier circuit (without output), a dry contact and buzzer will sound. The buzzer can be silenced by the switch below the LED.

9. VOLUME CONTROLLERS

Individual volume controllers are available for message playback (MESSAGE), siren tone (SIREN), handheld emergency mic with PTT (EMER MIC) and tone controls (TREBLE, BASS).

10. INDICATION & SIGNAL LEDs

Various LEDs to indicate the status and signal conditions of the unit with :

Clip	- When the mixed audio exceeds + 4 dBU
Signal	- Indicates signal level with -10 and -20 dB level
Temp	- Lits when internal temperature at heatsink exceeds 70 deg C
Standby	- Indicates the amplifier is in standby mode to allow standby power saving when there is no incoming audio Standby mode is set at DIP Switch 9 (ON - standby mode active)
Fault	- Lits when the self diagnostic system detects the amplifier module is faulty
Power	- Indicates AC mains power

11. MONITOR SPEAKER

The monitor speaker is to listen to mixed audio after Master volume, driven by a small speaker and available with volume control.

12. CHANNEL VOLUME CONTROLS

Individual channel's input volume are adjustable before being mixed. Each channel has its own LED indicator.

13. MASTER VOLUME CONTROL

The master volume control controls the output signal level, which will also affect the line output signal port at rear of device.

14. MASTER AC SWITCH

AC mains power switch to the device.

15. INCOMING AC MAINS

Incoming ac supply accepts voltage from 220 to 240V. The fuse rating is 10A. Earth terminal is provided if it is required to connect the body to the rack.

16. VENT FANS

The dual ventilation fans is temperature controlled with dual speed.

17. ANTENNA CONNECTOR

The antenna connector is for FM radio reception.

18. EXT UNIT OUTPUT

This is to link to slave unit EVS8820 as an extension to amplifier power and zoning. Please refer to section " Connecting Extension Amplifier ".

19. MASTER OUT

Master out is line level audio output which can be used to connect to additional amplifier to boost the total power.

20. START ADDRESS

Set the start address of EVM8810 which will be the first zone number of the device. This will allow the device to be used in a system of mix configurations / multiple block systems. If set the address as 1001 0000 00, the start of the zone will be zone 9 to 16 for the unit.

Tab 10 of the DIP switch is for paging active delay of 5min. Set to ON to limit the paging active time to 5 min while in OFF mode, the paging time is indefinite, which can be used for longer paging period such as during praying time.

Tab 9 of the DIP switch is to set the device whether to enter standby mode in the absence of incoming audio or otherwise.

Parts Identification

21. DATA PORT AND AMP FAULT CONTACT

RS485 data port is used to allow communication to other devices such as zone controls, emergency triggering and for firmware upgrading purpose.

EVM8810 comes with Auto Fault Sensing (AFS) feature. If amplifier module is faulty, which there is no output to the speaker with presence of incoming signal, the relay shall be closed. This can be used to connect to external indicating device or external amplifier changeover.

22. REMOTE MESSAGE TRIGGER

The saved internal messages (4 banks) can be triggered via front panel switch or remotely by devices such as Amperes FI6000 or wall switches. Remote messages triggering will have lower priority than the front switches, means when the remote trigger is activated, user has the privilege to override it to play other message.

23. 24V DC OUTPUT PORT

24V DC power source is available to power up other equipment in the system, thus no additional power supply unit to be installed. The max power rating is 3A.

24. RELAY CONTACTS

Relay contacts (NO type) will close whenever the handheld PTT mic, Message activated or when the trigger port is closed. The contact can be used to trigger external devices such as volume controllers, overriding patch panels, etc for volume overriding purpose.

The relay contacts be activated from local All Call or through remote trigger contact, subjected to requirement by user. This option on how the relay should trigger can be set. See also " Section 9, Page 11 "

25. STANDBY AMPLIFIER CONNECTIONS

EVM8810 comes with built in amplifier changeover relay. Standby power amplifier (recommended of the same rating) can be connected to the unit at the IN terminal and loop to the next EVS8820. Please refer to the section " Connecting Standby Amplifier " for details.

26. MUTE LEVEL CONTROL

Line inputs 1 and 2 will have priority over BGM inputs (Channel 1 to 6). The muting level can be adjusted to duck the levels of the BGM sources and shall resume to normal after 2 seconds. Adjust clockwise to adjust the muting to max (total mute) and in anti clockwise mode, the level can be mixed to the preference of the user.

27 INPUT CONNECTORS

Input channel 1 to 6 mini Phoenix connectors are for incoming audio signal in balanced mode. Each channel allows mic or line level selection by a slider switch. Switch to M for mic level and L for Line level.

28. LINE INPUT (UNBALANCED RCA JACKS)

Connect external player with stereo unbalanced line level to these jacks, available for input channel 7 and 8.

29. REMOTE PAGING MIC INPUT PORTS

Amperes PD series of paging microphone can control zones for EVM / EVS. There are two ports available for direct termination to the unit. In the event that more than one paging mic is used in the setup, use mic external mic connection unit EX2800. If the mic is located a distance away and return to the device using 2 pair screen cable, use RJ45 to connect to adapter to terminate, with the pin configuration shown at the panel.

30. EXT EP MIC INPUT PORT

External emergency paging mic, such as EP1200 which can be installed separately from EVM8810, is to be connected at this port. The pin connections are shown at the rear panel.

Activating external EP will have lower priority as compared to the handheld PTT mic located at the front panel.

31. GROUP A SPEAKER ZONE OUTPUTS

Speaker zones 1 to 4 outputs are linked to the internal amplifier.

32. GROUP B SPEAKER ZONE OUTPUTS

Speaker zone 5 to 8 outputs can be either linked to the internal amplifier or powered from external booster amplifier. To connect to internal amplifier, link the 100V terminal (Group A) to input terminals (Group B).

In case external amplifier is used, which in situation where the loading exceeds the capacity of the unit, the booster amplifier's output will connect to Input terminals (Group B). Please refer to section " Connecting External Amplifier ".

General Schematic Diagram

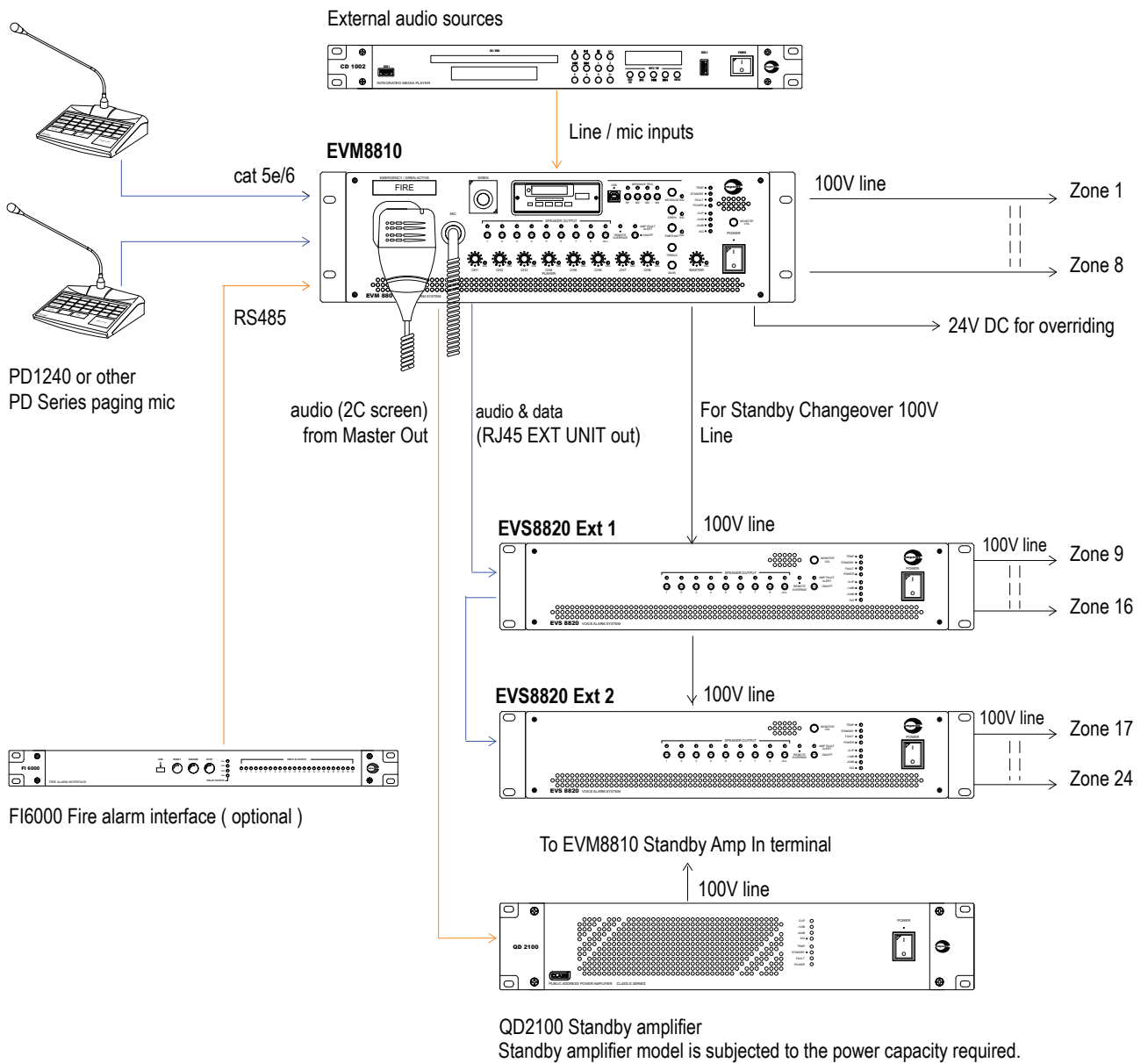

The above diagram illustrates typical configurations using EVM8810 serving Zone 1 to Zone 8 and links to EVS8820 serving Zone 9 to 24. All Amperes PD series of paging microphones can be used in the setup.

Please refer to Connecting the Unit for standby amplifier changeover connections.

General Schematic (Interface to iPX System)

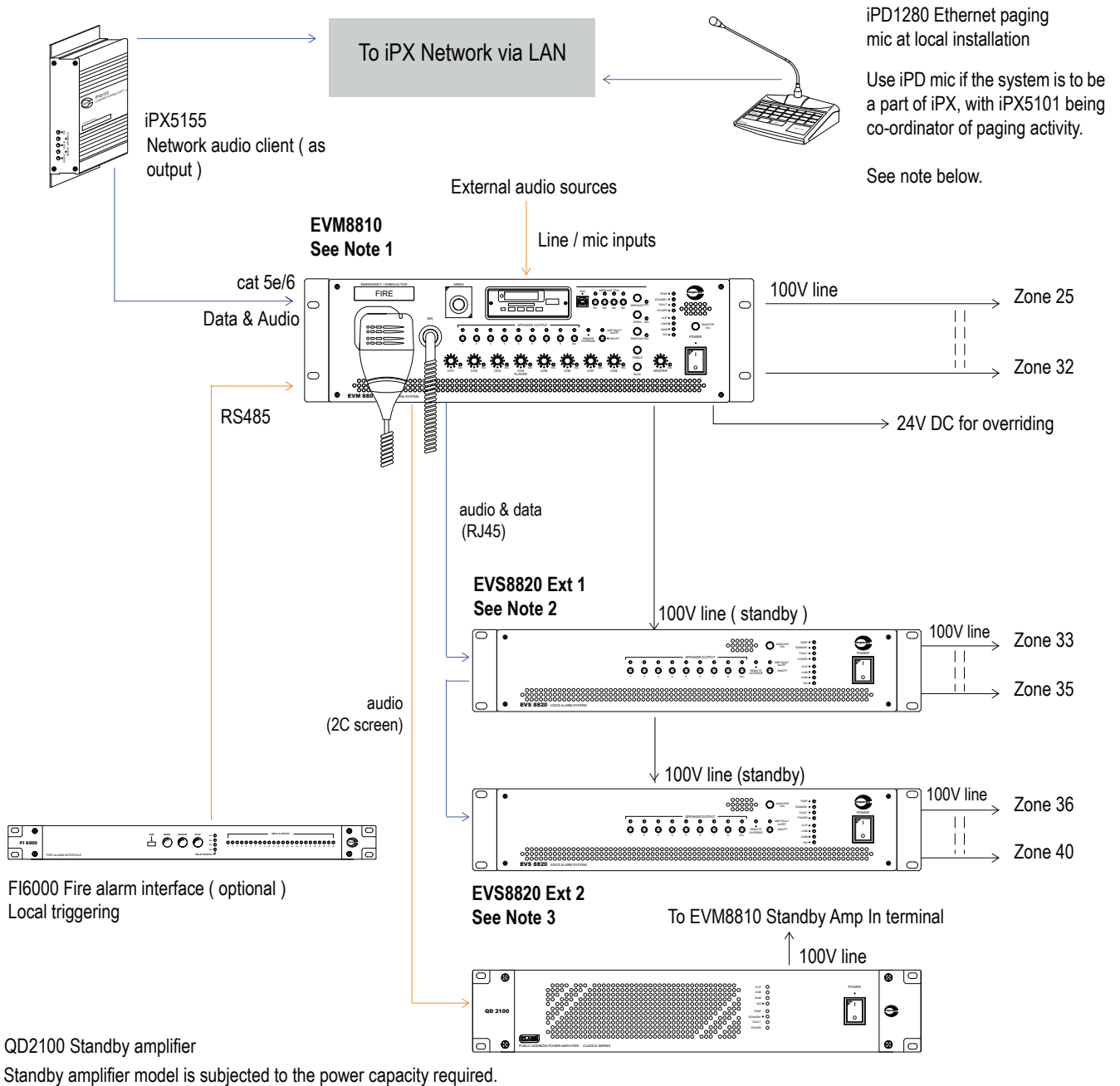

The diagram above shows connection of local installation using EVM8810 to Amperes iPX system. In this case, the iPX5155 shall be assumed as another paging mic. The priority accorded to iPX5155 can be set at central iPD paging mic. Since it is a part of a larger setup, the starting address may be differently configured.

Note 1 : Starting address as 25. The DIP switch shall be set to 1001 1000 11. It shall serve zone 25 to 32.

Note 2 : Starting address as 33. The DIP switch shall be set to 1000 0100 10. It shall serve zone 33 to 35, presumably the total loading exceed the capacity of the amplifier and would require another set of amplifier to cater the loads.

Note 3 : Starting address as 36. The DIP switch shall be set to 0010 0100 10. It shall serve zone 36 to 40,

In local installation within iPX setup, normal PD1240 / 1280 not recommended to be used as it may cause confusion in zone distribution and priority level protocols. Use iPD1280 and connect to the network instead. At the iPX5155, set the zone range.

If PD1280 is used, connect to another iPX5155 as input and thereafter to LAN.

General Schematic - Extending Zones With TD6400

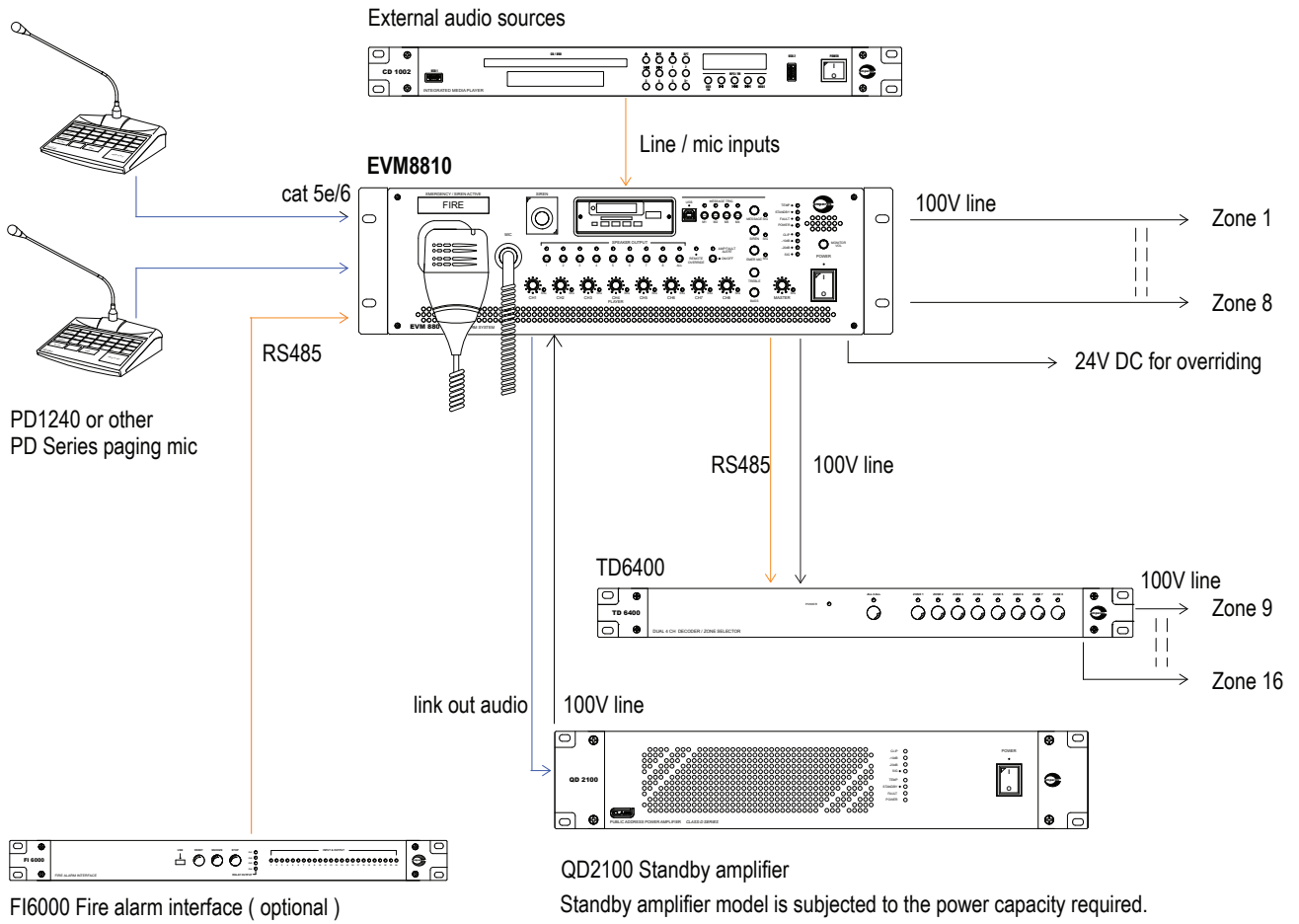

If in a system which there are more than 8 zones but the total load is below the capacity of EVM8810, the zones can be extended by using external zone selector (TD6400), without having to add another unit of EVS8810.

Zone extensions can be done by using TD6400 or combination of TD6240 + ZS5061 / 5121.

For detailed connections, refer to section " Extending Zones with TD6400 "

Connecting the Unit

1. CONNECTING THE ANTENNA

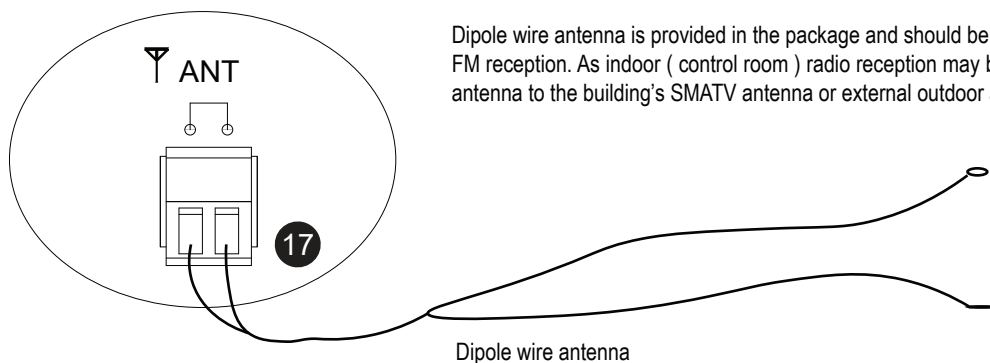

2. INPUT AUDIO (MIC / PLAYER)

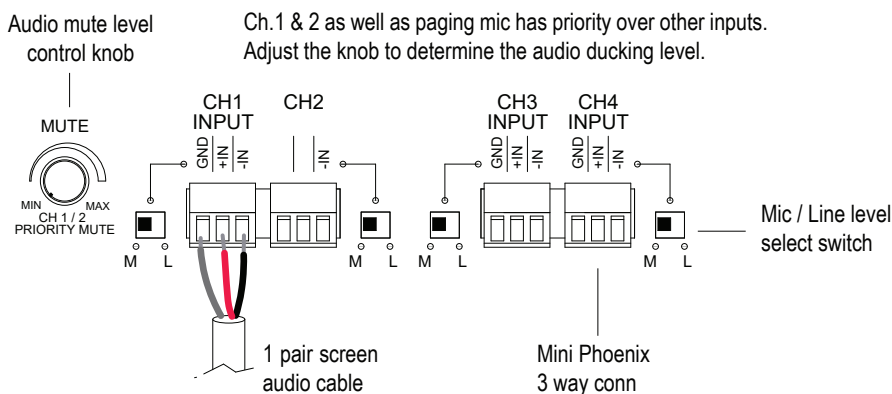

Incoming audio inputs are balanced type which can be in Mic or Line level, available for Ch.1 to Ch.6. The slider has M and L marking which is Mic and Line respectively. Switch to correct position corresponding to the incoming audio level.

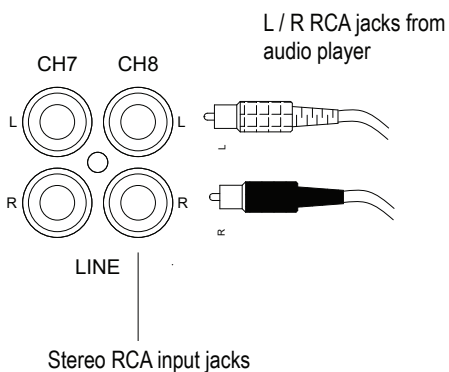

2 Channels for external BGM player using RCA jacks are available. Connect the stereo jacks to Channel 7 and 8. Although the incoming is stereo, it shall be converted to mono in the device.

Connecting the Unit

3. REMOTE PAGING MIC (AMPERES PD1240, ETC / EMERGENCY PAGING MIC EP1200)

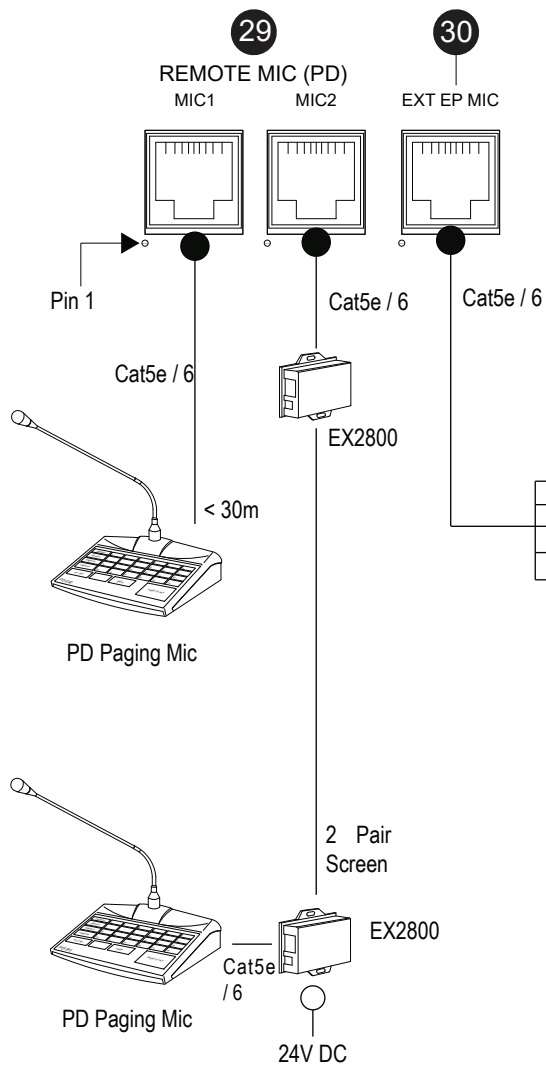

There are 2 ports for connecting the device to external Amperes paging microphones. Recommended paging microphones are PD1240, PD1160 and PD1900. If there are more than 2 paging mic, use mic extender EX2800, as shown in the instruction manual of the respective paging mic models.

EP1200 (connect Main audio out and relay contact)

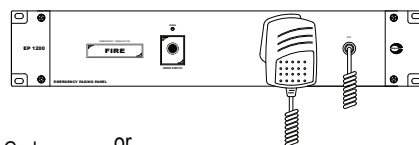

or

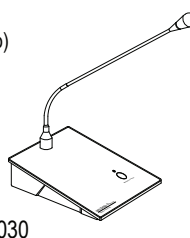

External mic can be used as an emergency paging mic by connecting to port "EXT EP MIC". Front handheld mic has the highest priority than external mic.

EXT EP MIC

RJ45 PINOUT:	
1) GND	5) +24V
2) TRIG	6) +AUDIO
3) NC	7) GND
4) GND	8) -AUDIO

The pin configurations of RJ45 port for emergency paging mic are :

MIC1 / 2 EXT LINK

RJ45 PINOUT:	
1) A	5) +24V
2) B	6) +AUDIO
3) NC	7) GND
4) GND	8) -AUDIO

The pin configurations of the RJ45 port for PD mic connections are as :

If EVM8810 is a part of iPX Ethernet Paging System, use iPX5155 (Set as Paging) and connect to one of the Remote Mic input port.

Zone setting in correspondence to EVM to be set at iPX5155.

Output audio and data of iPX5155 can be connected directly to the port or through EX2800.

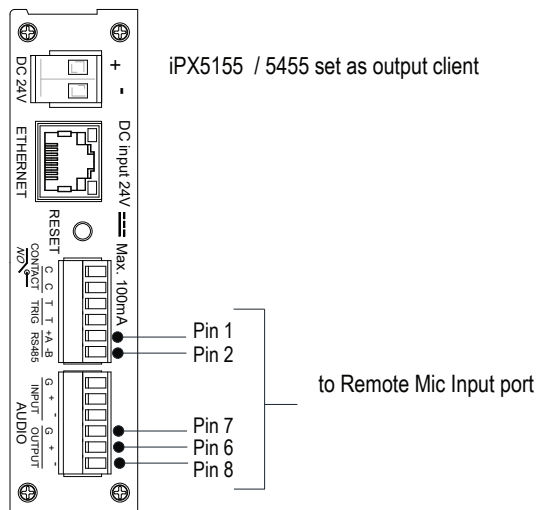

Connecting the Unit

4. FI6000 INTERFACE

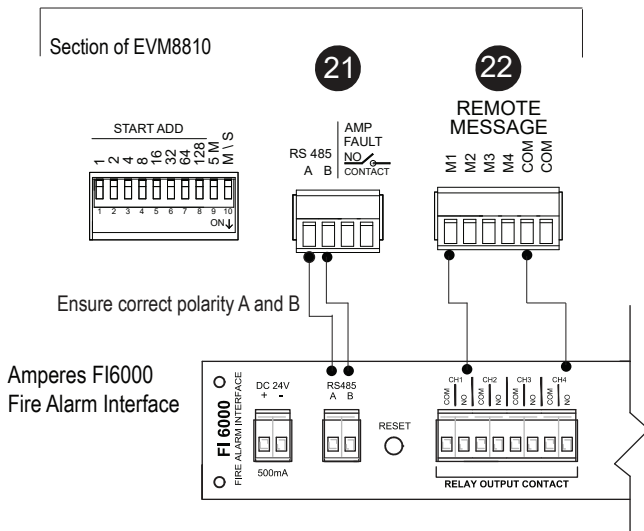

EVM8810 can be linked to external fire alarm panel through Amperes FI6000 to initiate EVAC message stored in the device and also to control the zone (s) in relation to the triggered channel of FI6000.

5. EXTENDING TO SLAVE UNIT EVS8820

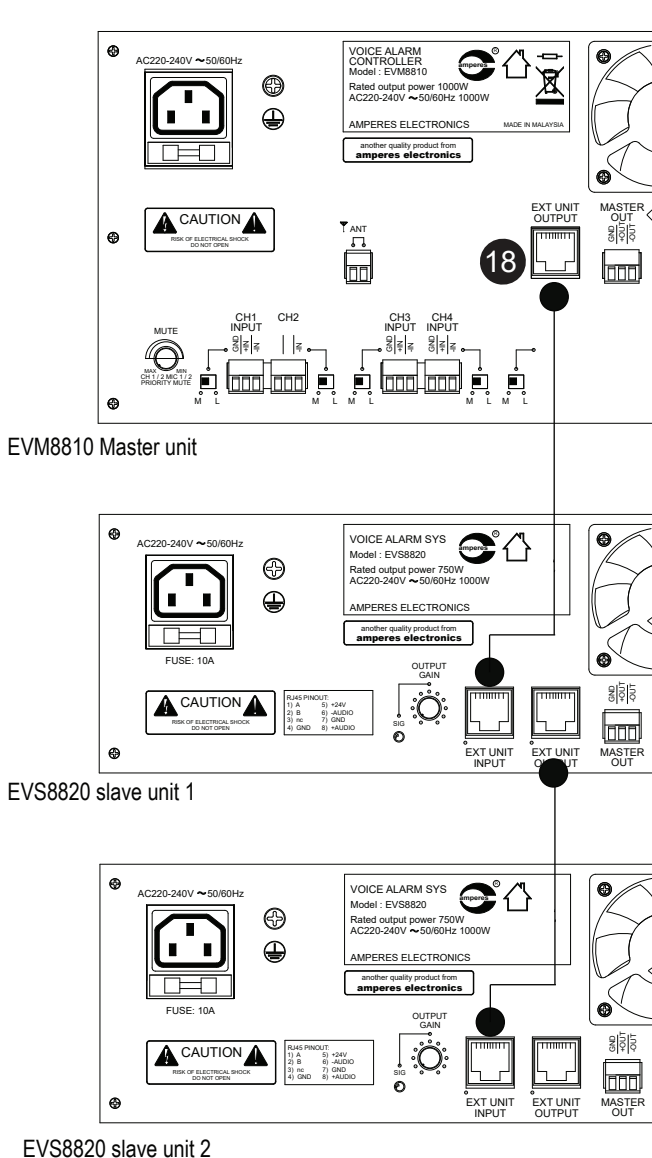

If more zones are required in a setup, the system can be expanded with additional slave unit EVS8820 of up to 2 units, forming a 24 zone system.

Use the EXT UNIT OUTPUT link with RJ45 / Cat5e to connect to EVS8820 EXT UNIT INPUT port.

➔ Zone 1 to 8
Setup address : 1000 0000 10

➔ Zone 9 to 16
Setup address : 1001 0000 00

➔ Zone 17 to 24
Setup address : 1000 1000 10

Connecting the Unit

6. INPUT AUDIO (MIC / PLAYER)

The Master Out connector provides balanced line audio to be connected to external power amplifier such as standby amplifier or for any other audio link.

The output is subjected to the output level of main output volume with max of 0 dBu.

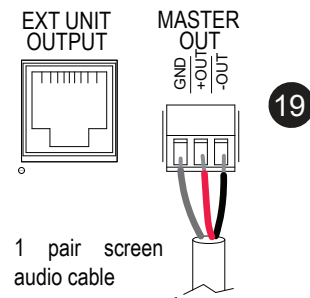

7. RS485 & AMP FAULT CONTACT

The RS485 is used to extend communication interface with external devices such as zone controllers (TD6400), emergency triggering, etc.

EVM8810 comes with internal Auto Fault Sensor (AFS). If the amplifier is faulty, this contact will close, which can then be used to activate external amplifier changeover unit or to trigger any external alerting device.

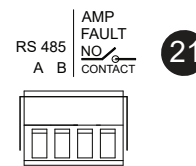

8. REMOTE MESSAGE TRIGGER

The 4 messages (message banks) can be triggered from front switches as well as remotely, either using momentarily switches or automated by Amperes FI6000.

M1 will have priority over M2 -- M3 and lastly M4.

When M4 message is playing, incoming M3 will override M4. Once M3 message has been completed, the M4 message shall resume.

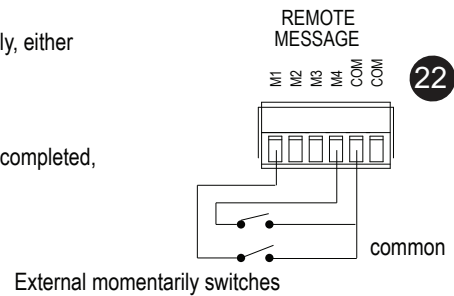

9. 24V DC OUTPUT AND VOLUME CONTROLLER OVERRIDING

A 24V DC port (Part ID. 23) is available to power any nearby devices without having to use external power supply. It can also be used to provide overriding voltage to external volume controllers. 2 relay contacts are available with NO and NC terminals.

Please ensure that the total loads must not exceed 3A if the internal 24V DC is used for overriding or any other powering purpose. If the relays total load exceeds this capacity, use an external PSU for overriding. Typically 100 units of volume controllers can be used for 3A power supply capacity.

The relay contacts are triggered when a message or the emergency handheld PTT mic is activated. It can also be triggered by shorting the TRIG terminals. Each relay contact port allows 10A current rating.

The relay triggering can be activated on Local All Call or when Remote All Call contact is activated. Example, when only an external emergency switch is triggered, it will only then provide relay contact to trigger the volume controller bypass.

The setup option for this feature :

Press ALL CALL button upon powering up the device and hold for 3 seconds. ALL CALL LED will blink slowly indicating the unit is entering configuration mode.

Press : Zone 1 - Local ALL CALL trigger relay active (Default : Off)
 : Zone 2 - Remote ALL CALL trigger relay active (Default : Off)

to exit setting mode, press and hold ALL CALL button for 3 seconds

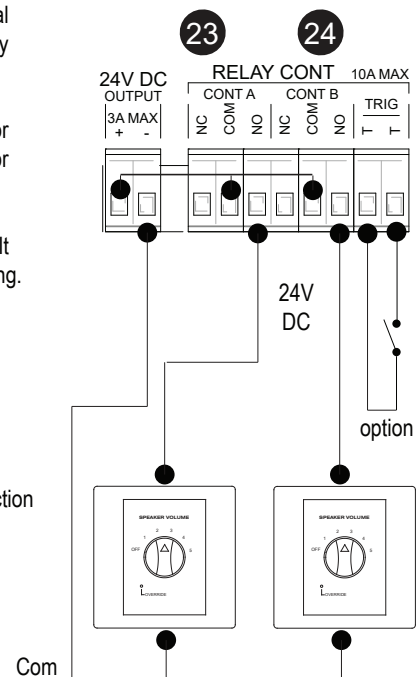

Note :
 100V line connection to VC not shown

Connecting the Unit

10. STANDBY AMPLIFIER CONNECTIONS

A standby amplifier must be able to cater for the overall loads. The output of the standby unit must be connected to the Standby Amp input (EVM8810). The standby output is then connect to the next slave unit and thereafter to the next slave unit.

In the event of the amp failure, the first unit will be taken over, followed by the second and third.

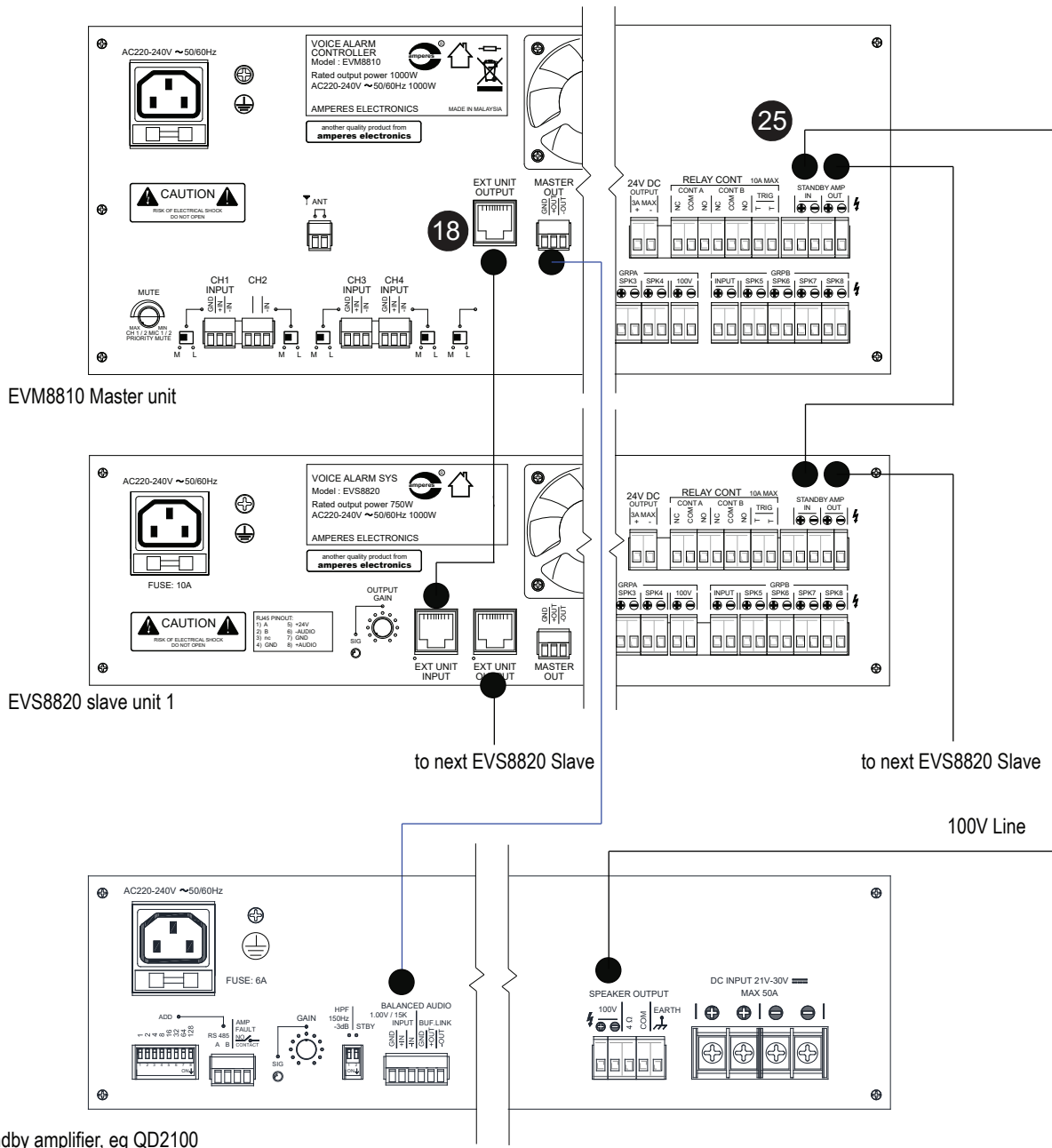

Standby amplifier, eg QD2100

Connecting the Unit

11. CONNECTING TO SPEAKERS

There are 8 zones available for speaker line distribution sharing the same amplifier output from the unit and divided into 2 groups.

Group A zones are directly connected to the internal amplifier, whereas the independent Group B can either link to the internal amp or using external 100V source if the controller itself cannot cater the load requirement.

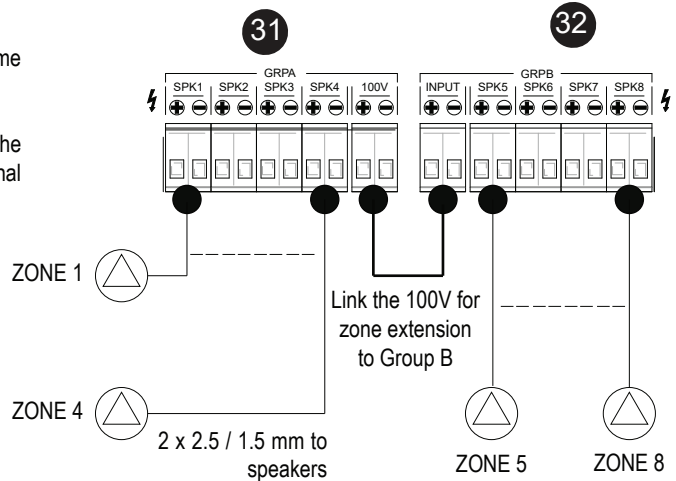

Loading EVAC Messages

4 files of messages can be uploaded to EVM8810 with total message length of 5 minutes. To upload message, plug the Printer-USB cable provided to the USB port of EVM (Part ID 5) and the B side of the cable to PC or Notebook.

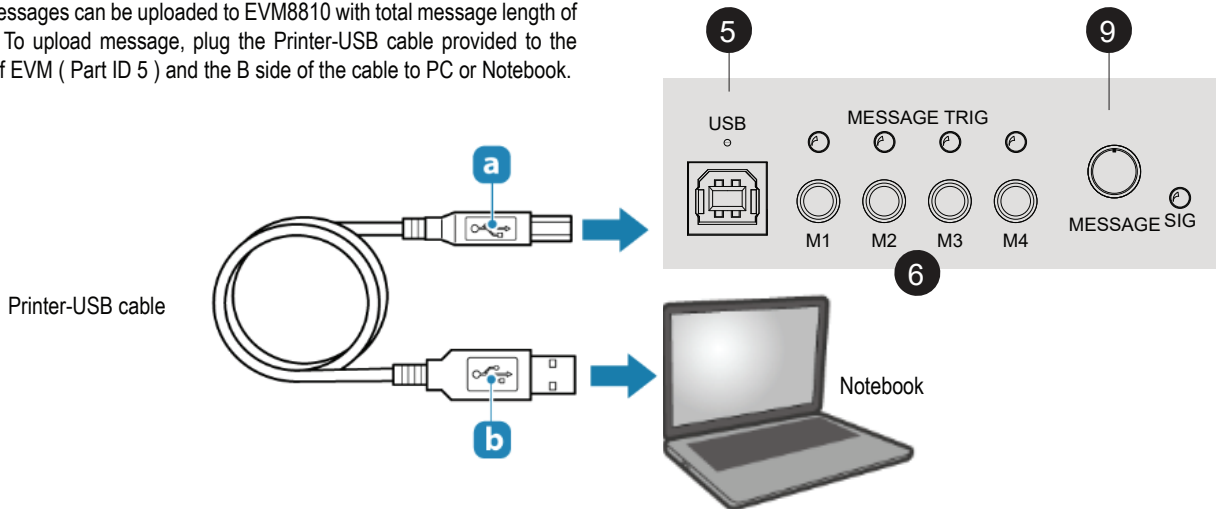

Once plug to the PC / Notebook, Windows will automatically detect it as a blank folder.

Transfer the required file to the folder with first file uploaded will be M1, second file be M2.. with the following name scheme :

- M1
- M2....
- M3....
- M4....

They are recognised by the leading letter / number and stored to the device accordingly.

Any changes to the file, or deleted file will alter the arrangement. As such, repeat the process with the first file to be M1 and so forth.

Files in PC

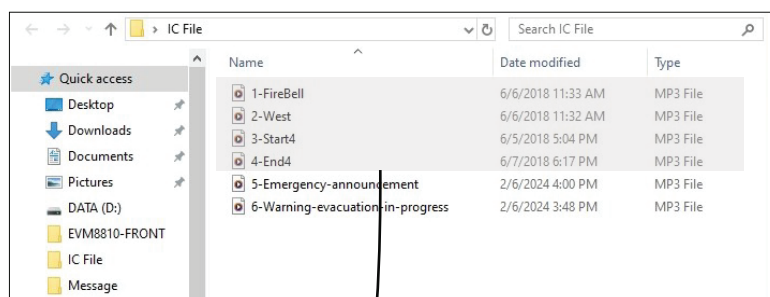

Transfer selected files

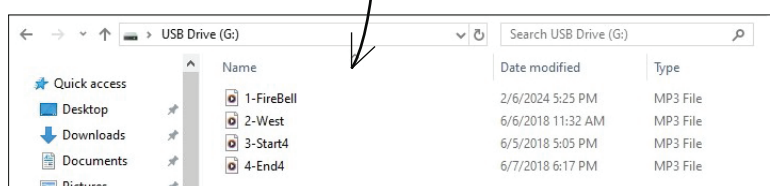

Files in EVM8810

Operating the Unit

1. EMERGENCY PAGING VIA HANDHELD PUSH TO TALK (PTT) MIC

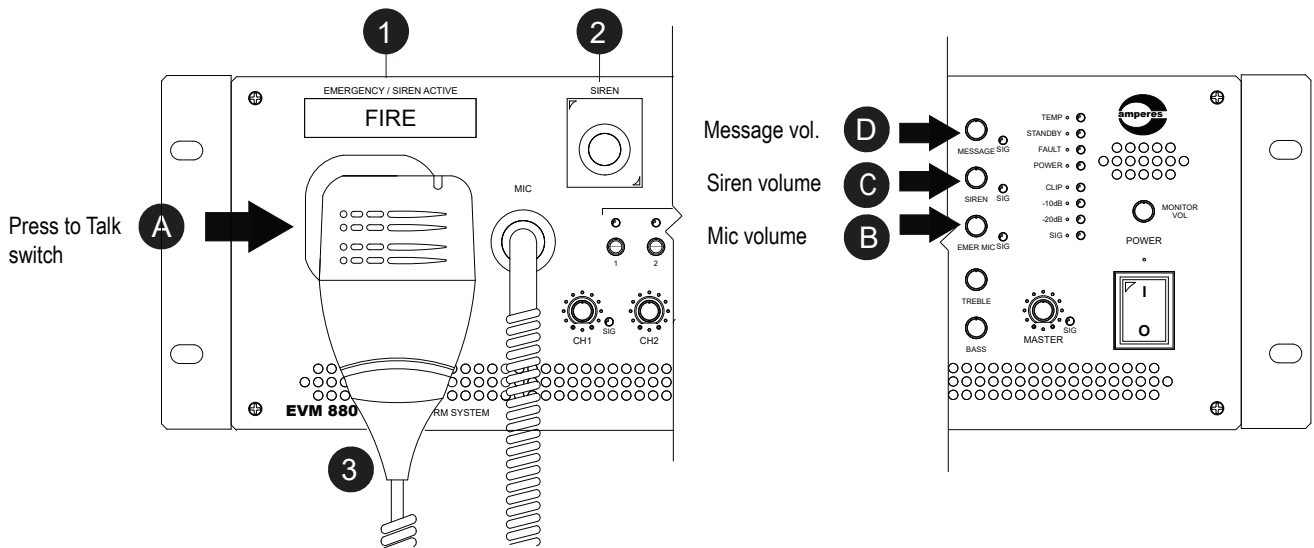

To make an emergency call, lift up the handheld PTT mic (Part ID 3), press the side switch (A) and start talking. All zones will be activated and the “Emergency / Siren Active ” display window will be flashing (Part ID 1).

To adjust the mic volume, use the knob “B”. Overall volume will be determined by the Master Volume Control knob.

This paging activity will have the highest priority of all incoming signals.

2. TRIGGERING SIREN

To trigger a siren, lift up the cover for siren switch (Part ID 2). Press the button momentarily and the siren tone will be broadcasted together with the flashing of “Emergency / Siren Active” display window.

Activating Siren will trigger All Call with relay contact closed (Part ID 24) located at the rear panel for volume controller overriding. The siren output can be adjusted using knob “C”.

3. MESSAGE PLAYBACK

4 Memory banks available for message storage and playback can be done from front switch (Part ID 6) as well as from rear triggering port.

Messages are marked M1 to M4, with M1 being highest priority. If M4 being played and interrupted by M2, it shall allow M2 file to play and after completion, the M4 file shall resume. The priority protocols between the front and rear activation are the same.

The playback volume can be adjusted using knob “D”.

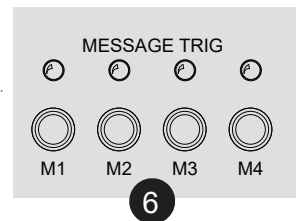

4. OUTPUT AUDIO MONITORING

Output audio can be monitored through the small speaker (Part ID 11). The output volume can be adjusted through the knob below the speaker holes.

The output is the summation of all input audios, with level after the Master Volume.

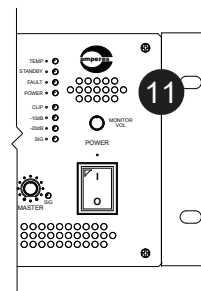

Operating the Unit

5. OTHER VOLUME CONTROLS

Other volume controls available are :

- Individual channel controls (Part ID 12) with specific channel 4 for media player
- Bass and Treble (Part ID 9).
- Master mixed volume (Part ID 13)

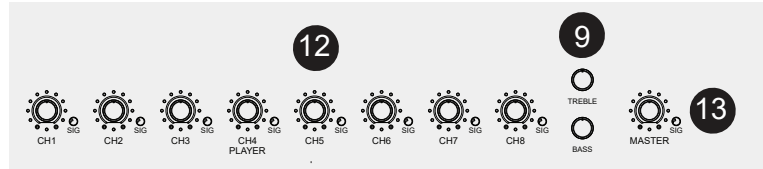

AUDIO PRIORITY SEQUENCE :

In compliance with EN / BS standards, the audio priority sequences are (Highest to Lowest) :

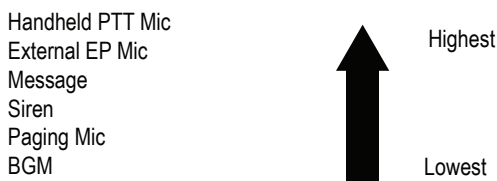

Operating the Unit - Media Player

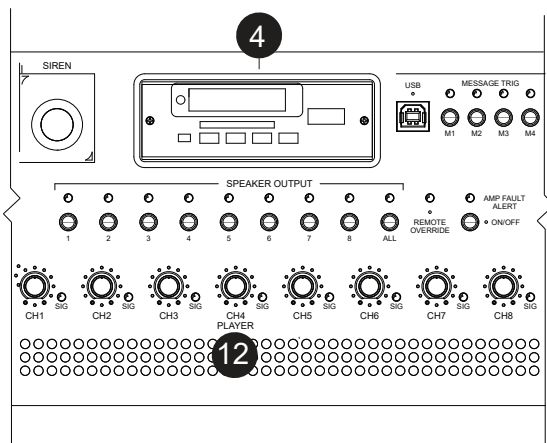

EVM8810 comes with integrated media player with FM tuner, SD card, USB and Bluetooth functions (Part ID : 4).

Other associated parts with the player are the speaker zone selection of which the zones requiring BGM can be selected. Whenever there is a remote paging, the BGM will be muted with "Remote Override" LED lits.

The volume adjustment for media is assigned to Ch.4. Adjust the music volume using this knob. If the media will be used in the system, do not connect the input Ch.4 at the rear panel. Otherwise both signals will be mixed.

1. THE MEDIA MODULE

- OFF/ON Button**
Power switch for the media player module
- Next, Prev & Volume Button**
The top button for repeating the previous song and to decrease the song volume while the bottom one shall skip to the next song and to increase the song volume.
- Play & Stop Button**
Press this button to play or to stop.
- Mode Button**
The menu at the display would switch between :-
RADIO ---- USB ---- SD ---- BLUETOOTH ---- RADIO

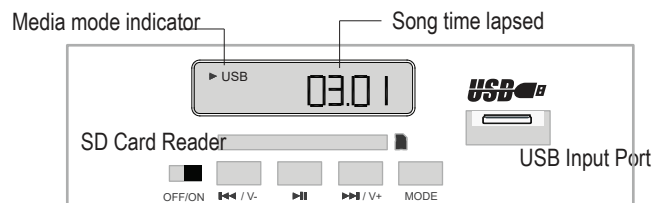

Operating the Unit - Media Player

2. PLAY USB / SD CARD

Insert a SD Card or USB into the slot and the unit shall automatically enter the playing mode. USB wording will be indicated at the left of the display.

Use the control buttons to adjust the volume, skip to next or previous songs, or alternatively using a remote controller provided.

3. PLAY FM TUNER

Press the MODE button until the FM indicator is displayed.

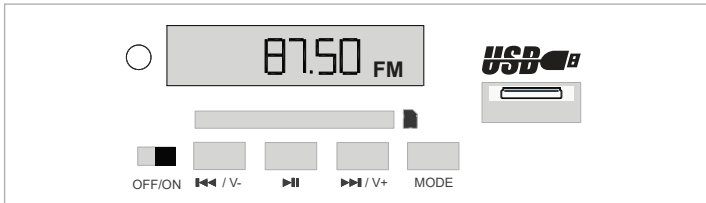

Use the 'Next' or 'Prev' button to manually select the station.

Auto program select. Press this button briefly and the tuner shall automatically search the stations.

4. BLUETOOTH

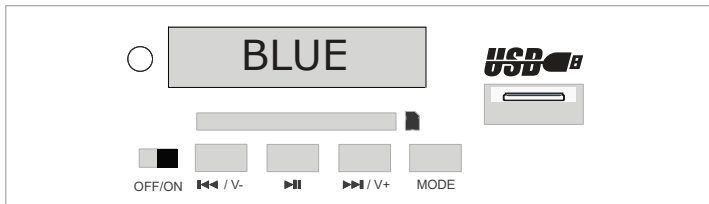

To enter the Bluetooth, press Mode button & Bluetooth reception mode shall be displayed.

Pair the media player with your Bluetooth player / Smartphone and once successfully paired, you can stream the music from your external device to this media player.

5. REMOTE CONTROLLER

An infra red remote controller for the media player.

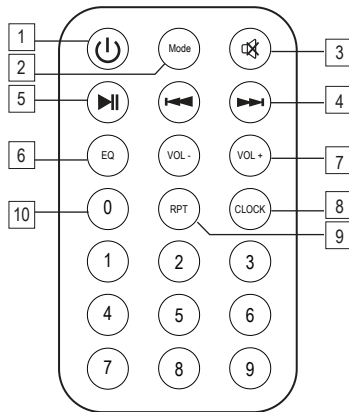

1. Power Switch : Press once to switch ON, press again to switch OFF.

2. Mode: Press this button to switch the radio / bluetooth / AUX / playback of USB / SD function.

3. MUTE : Press once to mute audio output, press again to resume volume level.

4. Next / Previous Button : In the playback mode, USB / SD songs, press this button to select previous song or next song. In the radio mode, it is for searching stations.

5. Play / Pause Button : Press this button to switch between Play and Pause.

6. EQ: Press this button to switch EQ modes (Jazz, Pop, etc)

7. VOL +/-: Press this button to increase or decrease volume level.

8. CLOCK: Press this button to switch to clock mode.

9. RPT: During playback, press RPT button briefly to play the current track repeatedly, and the LCD will display ONE. Press RPT button twice to play the tracks in the Folder repeatedly, and the LCD will display FOLD.

Press RPT button twice to play all the track, and the LCD will display ALL.

10. Numerical Buttons : In the radio mode, press this button to search the station. In the playback mode, press this button to choose desired songs.

Technical Specifications

Power supply	220 - 240 V ac : 50 / 60 Hz
Power rating (W at 100V line)	1000 W at 100 V line output
Power consumption (full load) : 240V ac	1500 VA (6.1 A)
Standby current at 240V ac	0.5 A
Input channels	Ch 1 to 6 Mic / Line bal, RCA x 2, handheld PTT mic, 4 X message banks Siren, PD paging mic x 2 ports, USB / MP3 / FM / BT, Ext EP1200
Input sensitivity / impedance	Mic : 40 mV / 10 kOhm Line : 1.2 V / 10 kOhm
Input signal at standby	Switchable auto detect / always ON
Frequency response	20 - 18 kHz (+/- 3dB @ 1kHz, 0 dBU)
THD (+ Noise)	< 0.2 %
Standby amplifier changeover	Built in changeover relay
Zone output	8 zones (front switch and remote paging with All Call)
Audio output	Master line output, balanced 0 dBU
Audio link to slave	Line balanced 0 dBU
Emergency dry contact	3A ; NO relay
Tone controls	Bass (100 Hz), Treble (10 kHz), 15 dB slope
Output audio monitoring	Front speaker with volume controller
Controls	Individual channels, message, siren, emergency mic, bass & treble, master volume
Communication control	RS485 ; 19.2 kbps
Cascade / link	RJ45 port (line audio and RS485 data)
Cascade quantity	3 nos (total 24 zones)
Indicators	Signal, temperature, fault, power, message, and zone selection
Priority sequence (low to high)	BGM, paging mic, siren, message, ext EP mic, handheld PTT mic
Protections	Thermal, short circuit, overload and AC fuses
Cooling system	Auto temperature controls
Cut off temperature	75 Deg C
Dimensions (W x H x D) mm	482x 132 x 420
Packing dimensions	550 x 225 x 500
Net weight (kg)	10.8
Gross weight (kg)	12.8

Note:

The above specifications are correct at time of printing, but subject to changes without prior notice due to product improvements.

Warranty Conditions

Only Amperes Electronics Service Centres are allowed to make warranty repairs : a list of Amperes Electronics authorized service centres may be asked by the purchaser or send directly to Amperes Electronics Sdn Bhd at 70 Jalan Industri PBP3, Tmn Perindustrian Pusat Bandar Puchong, 47100, Puchong, Selangor. This warranty is not valid if repairs are performed by unauthorized personnel or service centres.

This warranty covers only repairs and replacement of defective parts. Cost and risk of transportation as well as removal and installation of the product from the main system are for the account of the purchaser. This warranty shall not extend to the replacement of the unit.

This warranty does not cover damages caused by misuse, negligence in application as well as using the product with power supply voltage other than shown on the product, or any other power supply source / adapter not recommended by the manufacturer.

This warranty does not cover damages caused by fire, earthquakes, floods, lightning and every cause not directly related to the unit.

This warranty does not include any indemnity in favor of the purchaser or the dealer for the period out of use of the unit, moreover the warranty does not cover any damages which may cause to the people and things during the use of the product.

This warranty certificate is valid only for the described product, and is not valid if modifications are made on this certificate or identification labels applied to the unit or any other modifications to the physical unit other than its intended usage.

This warranty covers all the material and manufacturing defects and is valid for a period of 36 months from the date of purchase or for a specified period in countries where this is stated by a national law. In this case, the extension is valid only in the country where the product is purchased.

Amperes Electronics Sdn Bhd is not obliged to modify previously manufactured products under warranty if the design changes or improvements are made.

The purchaser is deemed to agree to the above warranty conditions once the product packaging is unpacked., Otherwise the product shall be returned to the seller in proper original condition.

Disclaimer

Information contained in this manual is subjected to change without prior notice and does not represent a commitment on the part of the vendor. Amperes Electronics Sdn Bhd shall not be liable for any loss or damages whatsoever arising from the use of information or any error contained in this manual.

It is recommended that all services and repairs of this product to be carried out by Amperes Electronics or its authorized service agents.

Amperes products must only be used for the purpose they were intended by the manufacturer and in conjunction with this operation manual.

Amperes Electronics Sdn Bhd cannot accept any liability whatsoever for any loss or damages caused by service, maintenance or repair by unauthorized personnel, or by use other than that intended by the manufacturer.



Registered to certificate: 16895/ A/ 0001/ UK/ En



AMPERES ELECTRONICS SDN BHD
MADE IN MALAYSIA
Published : MAY 2024