

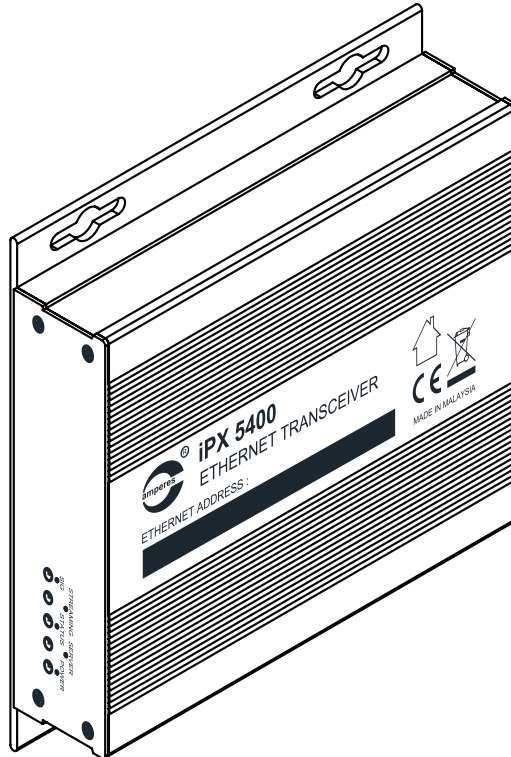

# INSTRUCTION MANUAL

## iPX5400

Ethernet Transceiver  
( audio & data )



improved version  
ultra low latency

*Thank you for choosing another quality product from Amperes Electronics.*

Introducing another product for the convenience of installation when it is required to send audio / data from a distance away. iPX5400 is a transceiver unit, which is able to operate in duplex mode ( paging ), works in pair in LAN environment or connected directly via UTP cable or Fiber through a converter. It is a simple device allowing peer-to-peer communication without the need to employ full IP solutions in your system.

Among applications includes :

- Sending audio from Guard House's paging mic to main system at a distance away through fiber link thus reducing the risks of lightning surge
- Rack-to-rack audio / data transmission through existing LAN, thus avoiding the need to lay new cables
- Apply it with wireless AP for areas where laying of new cables are not feasible.



Get more information and  
latest updates

  
Ver 2 / 2023

# Parts Identification

Isometric View (left)

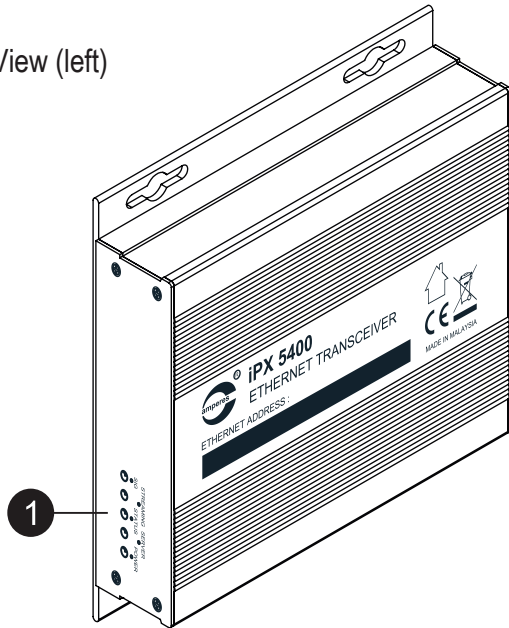

Rear View

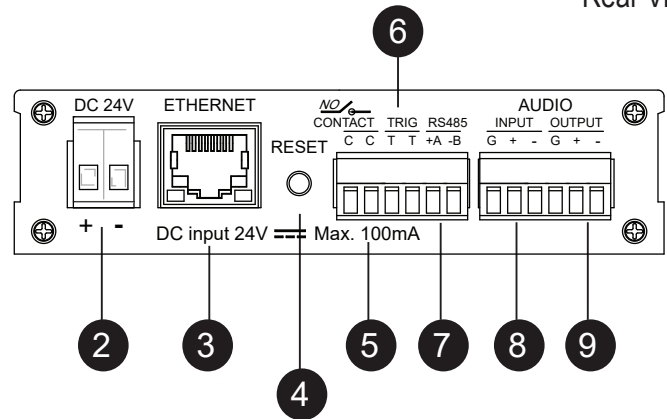

## 1. INDICATOR LEDS

LEDs for Power : Blue ( DC power connected), Server (when network connection established) , Status (when transmitter and receiver communicates ) and Streaming ( When transmitter is sending data / audio ), Signal ( will blink according to the audio volume )

## 2. POWER PORT

24V DC power supply input.

## 3. ETHERNET PORT

Ethernet Port for connection to network switch.

## 4. RESET BUTTON

Press to enable iPX5400 to enter bootloader mode or reset the unit to factory settings.

Bootloader mode : Press and hold until Power, Server and Status LEDs lit. This mode enables firmware updating if normal updating not possible. All data saved previously will remain.

Reset mode : Press and hold until Power, Server, Status and Streaming to reset the unit. All data will be lost.

## 5. RELAY CONTACT

Activating transmitter remote trigger will activate receiver Relay Contact with NO. Can be used as E/M relay contact to override signal or to trigger All Call

## 6. REMOTE TRIGGER PORT

This contact from transmitter when closed shall trigger Relay Contact at receiver

## 7. RS485 PORT

For RS485 data transmission from PD paging mic to activate zone decoder / selector connected with receiver.

## 8. AUDIO INPUT PORT

Connect audio input with balanced line level from paging mic or other BGM source.

## 9. AUDIO OUTPUT PORT

Output received shall be balanced line level, to connect to external mixer, amplifier, etc.

# Application Example

iPX5400 is used to transmit audio or data, or both from one location to another through LAN or directly from iPX5400 set as transmitter and to the other end set as receiver.

Among reasons why iPX5400 can be used are :

- Whenever new cabling is no longer possible to be laid, iPX5400 would come in handy to send audio via existing LAN.
- When the distance from one location to another is too far which would encounter noise issues when using normal copper cable. In this case, fiber link would be the right solution.

## Connectivity Example : Peer-to-Peer Direct

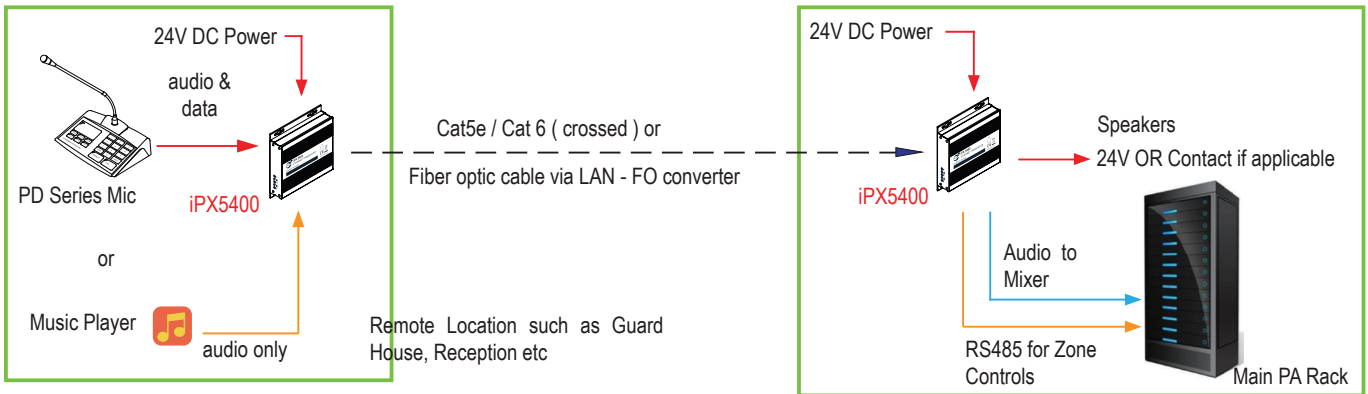

## Connectivity Example : via LAN

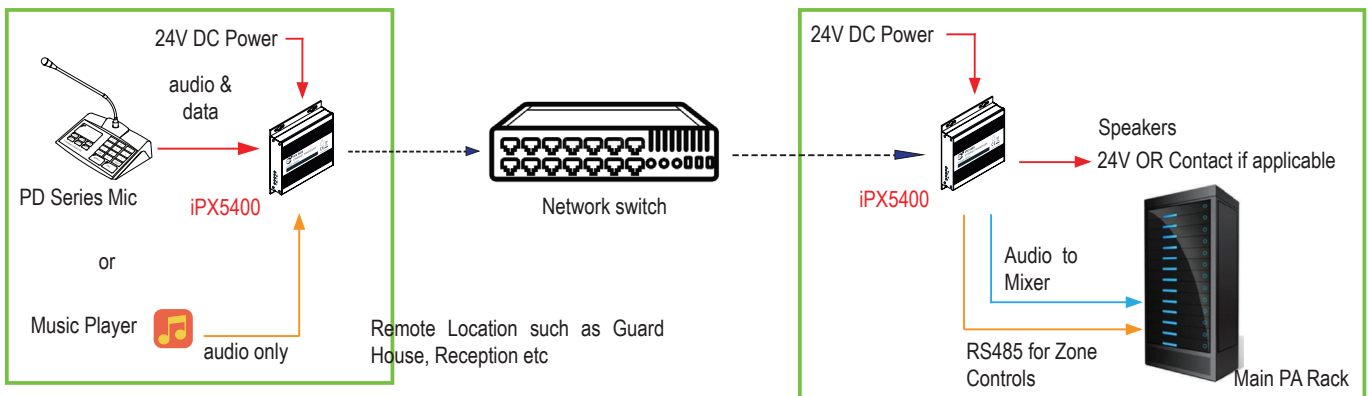

Cat 5e / 6 cable shall not exceed 80m when connecting iPX5400 to a network switch. As iPX5400 is a non PoE device, a local power source is required.

# Application Examples

## 1. CONNECTING AMPERES PD PAGING MIC TO IPX5400

This is usually applied when it is required to install a paging microphone a distance away from the rack such as guard house, remote office or at different building.

Audio ( line level output ) and RS485 output shall be connected to iPX5400 as per diagram below, and at the receiving end, audio shall be fed to mixer and the RS485 data shall go to TD decoder for zone activation. In this mode, duplex operation is allowed.

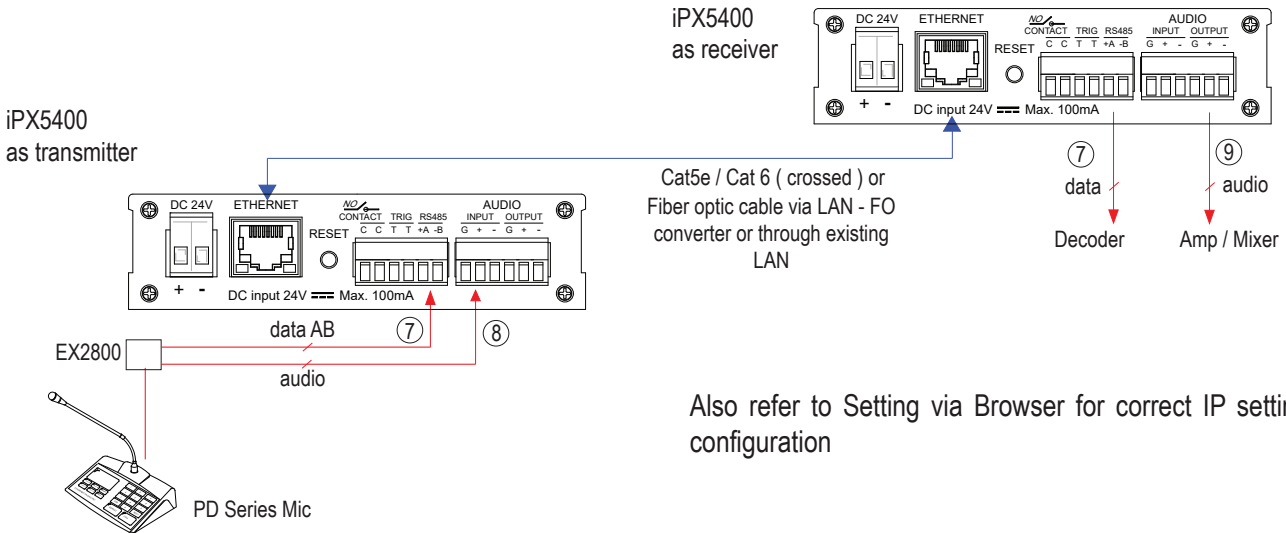

## 2. CONNECTING ANALOGUE PM MIC VIA DRY CONTACT ACTIVATION

Normal mic such as PM1000 can use to transmit with a dry contact as activation key. At the receiving end, there shall be audio output for link to mixer, etc and another dry contact for other general purpose. An example is to use a handheld mic as emergency mic at guard house to trigger an ALL CALL at system rack for emergency announcement.

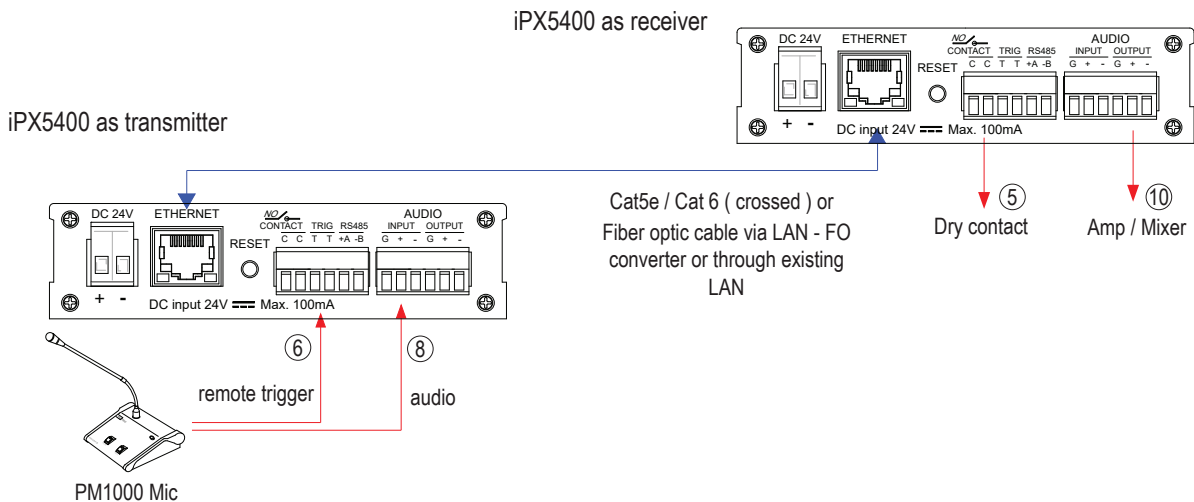

# Application Example

## 2. TRANSMITTING MUSIC / AUDIO

iPX5400 allows high quality music audio to be transmitted via existing LAN or fiber optic. They works in pair at simplex mode. Analogue input to iPX5400 shall be assigned as transmitter and the other end as receiver.

Set the audio transmission as "Always On", see page 9.

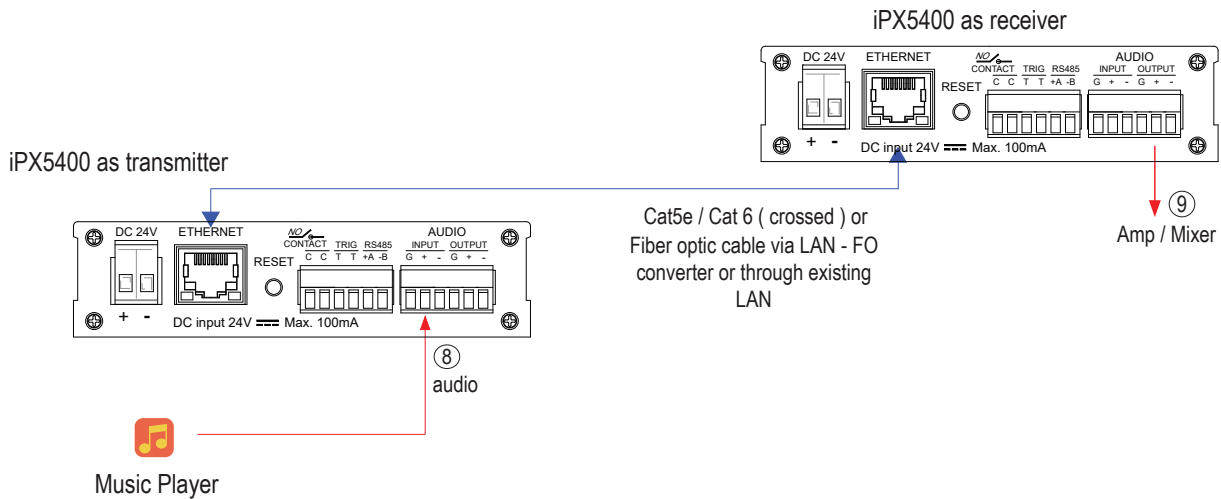

## 2. DUPLEX AUDIO

iPX5400 can also work in duplex mode but with lower bandwidth. Normally voice audio is suitable and not hi-definition music. It is suitable when both locations would require paging to and fro.

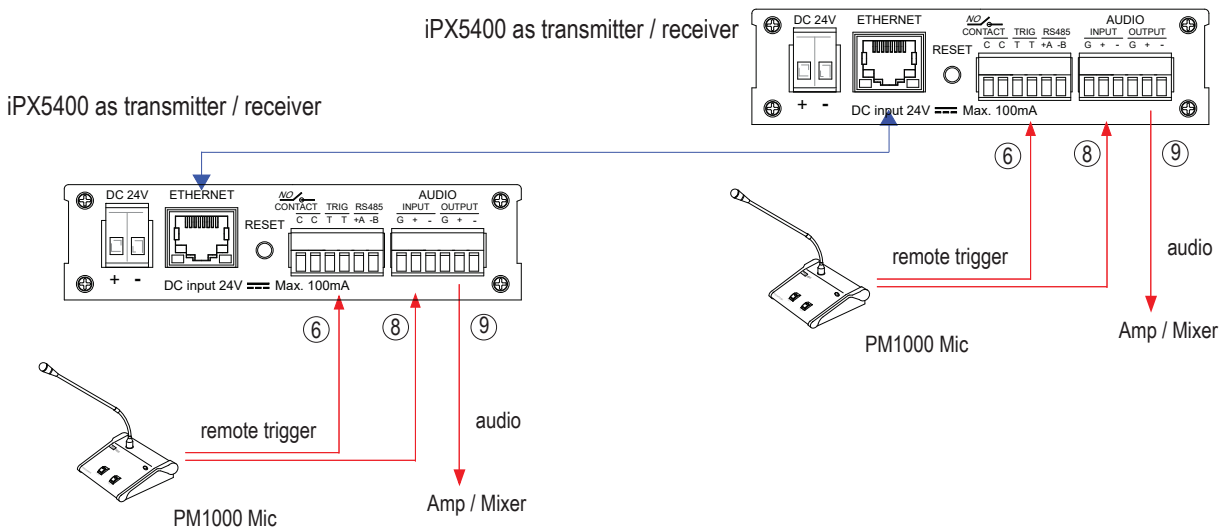

# Setup via Browser

Some simple setups via browser is required before using the device. Log into the system with default IP address at 192.168.0.100

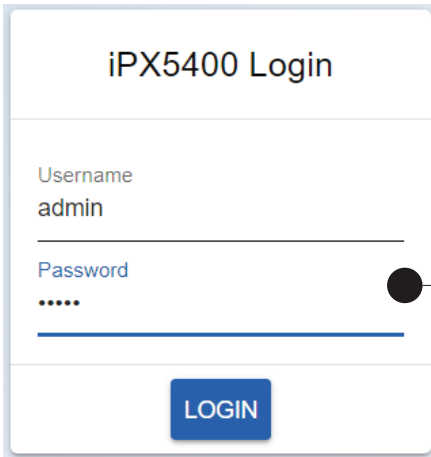

The login form is titled "iPX5400 Login". It contains two input fields: "Username" with the value "admin" and "Password" with masked characters ".....". A blue "LOGIN" button is positioned at the bottom center of the form.

Default Username and Password are both "admin". You can change this password and username.

## DEVICE INFO

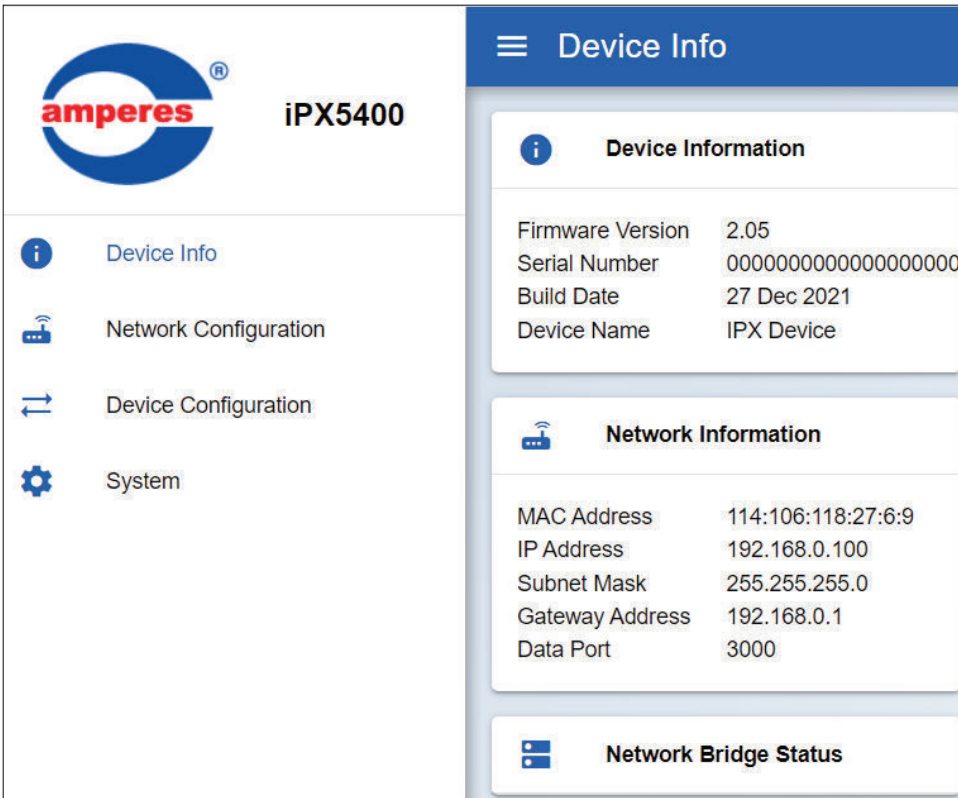

The screenshot shows the "Device Info" page for an Amperes iPX5400. The left sidebar contains navigation options: "Device Info" (selected), "Network Configuration", "Device Configuration", and "System". The main content area is divided into three sections: "Device Information", "Network Information", and "Network Bridge Status".

Device Information	
Firmware Version	2.05
Serial Number	00000000000000000000
Build Date	27 Dec 2021
Device Name	IPX Device

Network Information	
MAC Address	114:106:118:27:6:9
IP Address	192.168.0.100
Subnet Mask	255.255.255.0
Gateway Address	192.168.0.1
Data Port	3000

Network Bridge Status	
-----------------------	--

### Device Information

Shows the firmware version number, device serial with its build date and the default device name. The device name can be changed.

### Network Information

Info related to network communication is shown. IP address should be changed.

### Network Bridge Status

Shows status of connectivity to the other paired device.

# Setup via Browser

## NETWORK CONFIGURATION

The screenshot shows the 'Network Configuration' page for the Amperes iPX5400. The left sidebar contains navigation options: Device Info, Network Configuration (selected), Device Configuration, and System. The main content area is titled 'IPv4 Configuration' and includes the following fields:

- IP Address: 192.168.0.100
- Subnet Address: 255.255.255.0
- Gateway Address: 192.168.0.1
- Data Port: 3000

A green 'SAVE' button is located at the bottom right of the configuration area.

### IPv4 Configuration

Change the network IP address of the device and the gateway address if necessary.

Leave the data port at 3000.

The screenshot shows the 'Device Configuration' page for the Amperes iPX5400. The left sidebar contains navigation options: Device Info, Network Configuration, Device Configuration (selected), and System. The main content area is titled 'IPX Bridge Configuration' and includes the following settings:

- Auto Connect:
- Audio Transmission: Always On

A green 'SAVE' button is located at the bottom right of the configuration area.

Below the IPX Bridge Configuration is the 'Audio Configuration' section, which includes:

- Volume: 80%
- 5 Band Equalizer: 0<sub>dB</sub>, 0<sub>dB</sub>, 0<sub>dB</sub>, 0<sub>dB</sub>, 0<sub>dB</sub>
- Frequency sliders: 100<sub>Hz</sub>, 250<sub>Hz</sub>, 1<sub>kHz</sub>, 4<sub>kHz</sub>, 10<sub>kHz</sub>

A green 'SAVE' button is located at the bottom right of the audio configuration area.

## DEVICE CONFIGURATION

### IPX Bridge Configuration

Set the mode of connectivity to the paired device, either as auto connect or manual.

Please see following section at Page 9

### Audio Configuration

Enable volume setting of the device's audio output and the 5 band audio spectrum.

# Setup in Browser

## SYSTEM

The screenshot shows the 'System' configuration page for an Amperes iPX5400 device. The interface is divided into a left sidebar and a main content area. The sidebar contains the Amperes logo and the model number 'iPX5400', along with a menu of configuration options: Device Info, Network Configuration, Device Configuration, and System (which is currently selected). The main content area has a blue header with a hamburger menu icon and the title 'System'. Below the header, there are three sections: 'Unit Configuration' with a 'Device Name' field containing 'IPX Device' and a 'SAVE' button; 'Authentication' with 'Enter new username' and 'Enter new password' fields and a 'SAVE' button; and 'Update Firmware' with a large 'SELECT FIRMWARE' button.

### Unit Configuration

Device name can be changed to a unique name for easier unit identification, especially when there are multiple units installed in a system.

### Authentication

It is advisable to change the default username and password to a new one to prevent unnecessary access to the settings.

### Update Firmware

When firmware update is available, use this tab to perform the task. Check with webpage for any version changes.

Please see page 10 on how to update firmware.



# Setup in Browser ( Bridging / Pairing )

Connectivity to the pairing device can be set automatically or manually by defining the IP addresses of both the receiver and transmitter.

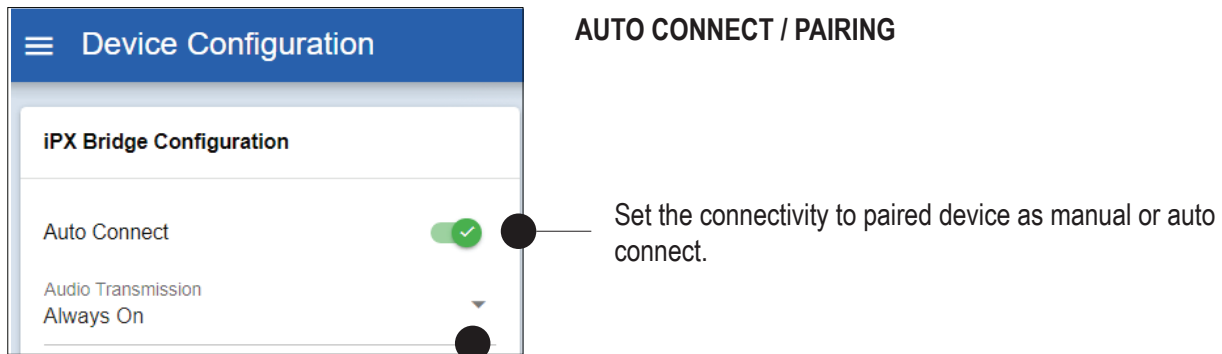

## AUTO CONNECT / PAIRING

Set the connectivity to paired device as manual or auto connect.

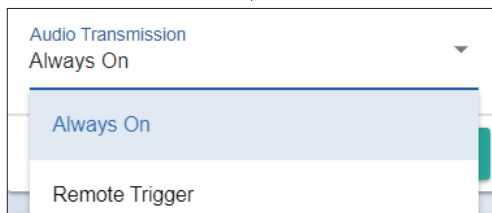

Audio transmission can be set to :

- Always On - audio is always transmitted / received
- Remote Trigger - audio is only transmitted whenever dry contact is available. See Application Example at Page 4.

## MANUAL PAIRING WITH FIXED IP ADDRESS

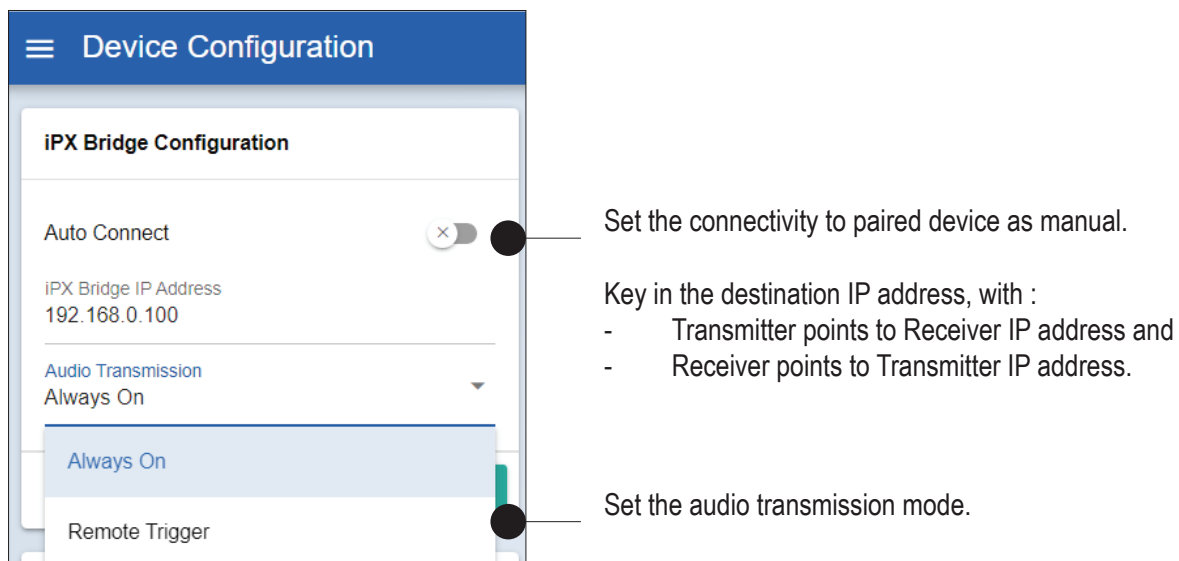

Set the connectivity to paired device as manual.

Key in the destination IP address, with :

- Transmitter points to Receiver IP address and
- Receiver points to Transmitter IP address.

Set the audio transmission mode.

# Update Firmware

**Update Firmware:** System firmware shall be updated once in a while when new features are available or to fix bugs.

There are 2 methods of doing so:

## UPDATE FIRMWARE IN NORMAL OPERATION MODE

1. Open a browser and type in the iPX5400 IP Address set previously. Transmitter and receiver may have different address.
2. Under "System" page look for "Update Firmware" section as shown below.

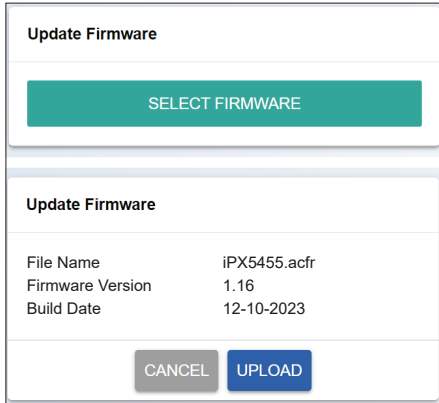

Click "SELECT FIRMWARE" and choose a binary file with ".acfr" extension. Click "UPLOAD".

Once the update is completed, the browser should enter the login page.

## UPDATE FIRMWARE IN BOOTLOADER MODE

If the iPX5400 "hangs", it is required to perform system reset by following the steps below:

1. Press & hold the reset button until "STREAMING" LED is turned ON. This will set the IP address to default address 192.168.0.100.
2. Open a browser and enter the IP address 192.168.0.100. A web page as shown below shall appear.
3. Select "Upload Firmware", choose a binary file with ".acfr" extension and click "UPLOAD".
4. Once the uploading is complete, the browser shall enter the login page.

Click the Upload Firmware button to find the updated firmware file.

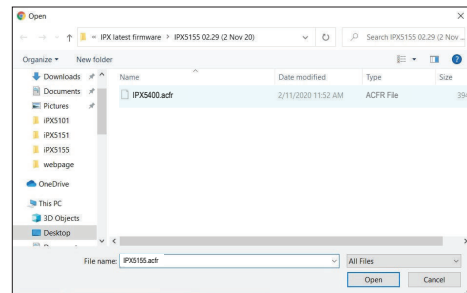
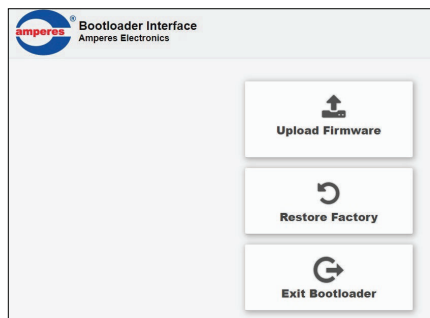

Find the updated firmware file.

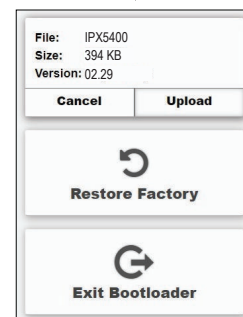

Ready to upload, click Upload button to upload the firmware.



Update in progress

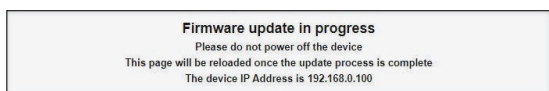
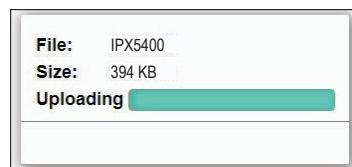

After finish updating firmware, the browser will automatically restart

## Summary of Features

- Low latency audio and data transceiver
- RS485 and voice at full duplex ; music audio at simplex
- IP Paging server / network switch not required
- Supports automatic link crossover
- Setup via browser, controllable via PMX software
- Supports 2 modes ;
  - Always On
  - On remote trigger or through API

## Technical Specification

Power requirement :	
Voltage	18 - 24V DC (Normal DC 24V)
Current	60 mA
Power consumption	1.5W
Connectivity	
- LAN interface	RJ-45, 10/100T Base
- Protocols	TCP/IP, UDP, IGMP, HTTP, UDMP, ADP
Audio	
- Analogue input ( max )	1.25 V rms (line)
- Analogue output (max)	1.25 V rms ( with max input 1.25 V )
- Input impedance	10K Ohm
- Input capacitance	100 pF
- Total harmonic distortion (THD)	0.1 %
- S/N ratio (full scale signal)	83 dB
User interface	Google Chrome, MS Edge
Firmware upgrade	Via Web Browser
Operating conditions	
- Temperature	-20 - 80 C
- Humidity	0 - 70%
Case :	
Dimension (WxHxD)	120 x 28 x 132 mm
Weight	300 g

### Note:

The above specifications are correct at time of printing but subject to changes without prior notice due to product improvements.

# Warranty Conditions

Only Amperes Electronics Service Centres are allowed to make warranty repairs : a list of Amperes Electronics authorized service centres may be asked by the purchaser or send directly to Amperes Electronics Sdn Bhd at 70 Jalan Industri PBP3, Tmn Perindustrian Pusat Bandar Puchong, 47100, Puchong, Selangor. This warranty is not valid if repairs are performed by unauthorized personnel or service centres.

This warranty covers only repairs and replacement of defective parts. Cost and risk of transportation as well as removal and installation of the product from the main system are for the account of the purchaser. This warranty shall not extend to the replacement of the unit.

This warranty does not cover damages caused by misuse, negligence in application as well as using the product with power supply voltage other than shown on the product, or any other power supply source / adapter not recommended by the manufacturer.

This warranty does not cover damages caused by fire, earthquakes, floods, lightning and every cause not directly related to the unit.

This warranty does not include any indemnity in favor of the purchaser or the dealer for the period out of use of the unit, moreover the warranty does not cover any damages which may cause to the people and things during the use of the product.

This warranty certificate is valid only for the described product, and is not valid if modifications are made on this certificate or identification labels applied to the unit or any other modifications to the physical unit other than its intended usage.

This warranty covers all the material and manufacturing defects and is valid for a period of 36 months from the date of purchase or for a specified period in countries where this is stated by a national law. In this case, the extension is valid only in the country where the product is purchased.

Amperes Electronics Sdn Bhd is not obliged to modify previously manufactured products under warranty if the design changes or improvements are made.

The purchaser is deemed to agree to the above warranty conditions once the product packaging is unpacked., Otherwise the product shall be returned to the seller in proper original condition.

# Disclaimer

Information contained in this manual is subjected to change without prior notice and does not represent a commitment on the part of the vendor. Amperes Electronics Sdn Bhd shall not be liable for any loss or damages whatsoever arising from the use of information or any error contained in this manual.

It is recommended that all services and repairs of this product to be carried out by Amperes Electronics or its authorized service agents.

Amperes products must only be used for the purpose they were intended by the manufacturer and in conjunction with this operation manual.

Amperes Electronics Sdn Bhd cannot accept any liability whatsoever for any loss or damages caused by service, maintenance or repair by unauthorized personnel, or by use other than that intended by the manufacturer.



ISO 9001: 2015  
Design & Manufacture of Public Address Equipment and Systems  
Certificate No. 16895 / A / 0001 / UK / En



AMPERES ELECTRONICS SDN BHD  
MADE IN MALAYSIA  
Published : JUL 2023