

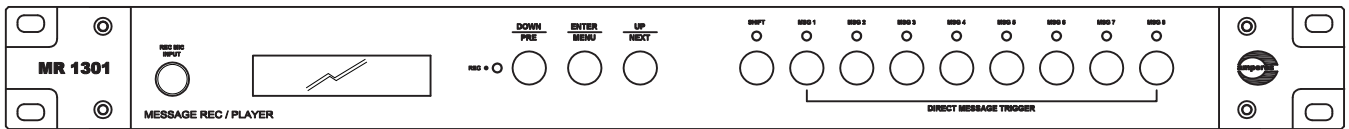

INSTRUCTION MANUAL

MR1301

Message Recorder / Player



Thank you for choosing another quality product from Amperes Electronics.

The all new MR1301 succeeded its predecessor with much improvements with emphasis taken on the stability, flexibility and performance in line with the increasing demanding expectations of a professional message recorder / player.

With the powerful 32 bit ARM processor, among the enhancement features include the larger memory size of SD card of up to 16GB, flexible arrangement of files / messages in every channel with delays in between messages, higher quality of voice recording and also RS485 links directly to PC or via IP (application with UART - IP Converter) for remote monitoring and controls.

The search of a true professional message player for application in Public Address system shall end here with the evolution of MR1301. While it is essential for emergency broadcast over the distributed speakers, it may be applied alongside with PT1800 / PT1801 programmable timer for pre-determined time message playback.

Parts Identification

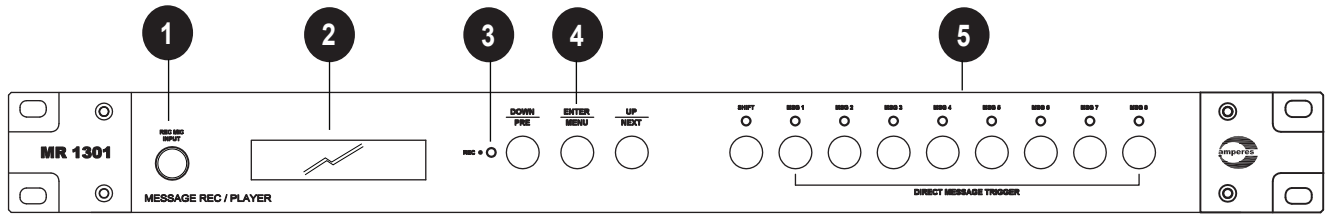

Front View

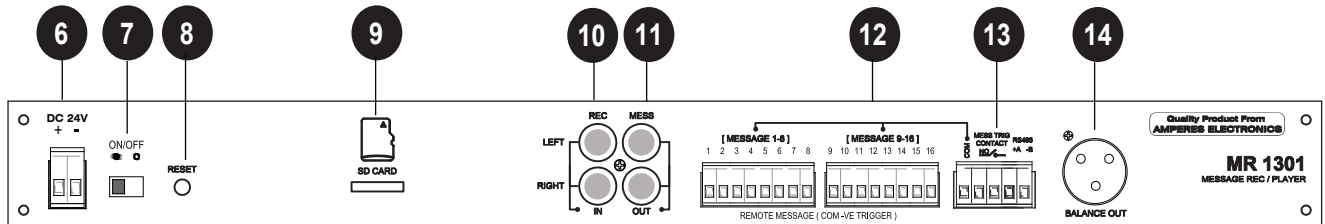

Rear View

1. 1/4" STEREO PHONE JACK

Stereo phone jack for microphone inputs with balanced input signal. Used for recording voice to the unit. It accepts recording via dynamic microphone.

2. LCD DISPLAY

2 X 16 characters LCD displaying unit's parameters and programming instructions.

3. RECORD LED

In recording mode, the red LED shall lit.

4. CONTROL BUTTONS

Buttons for Menu, various playback, recording and volume controls

5. FRONT MESSAGE ACTIVATION SHORT KEY

8 front short key for direct message activation ; MSG 1 to MSG 16 with LED indicators. Shift button is available for triggering message 9 to 16.

6. POWER CONNECTORS

24V DC input for power, use only regulated power supply or Amperes PS9400 power supply unit.

7. POWER SWITCH

Power switch for the unit.

8. RESET BUTTON

Button for resetting the unit to factory default. Use only when required as settings done previously would be lost. Voice files stored in the SD card shall not be affected.

Parts Identifications (continued)

9. MICRO SD CARD SLOT

SD card slot, up to 16 GB capacity is supported by the unit (Standard supplied card is 16 GB).

10. LINE INPUTS

RCA jack for recording from external source with line output, such as CD, MP3 players, etc.

11. LINE OUTPUTS

Unbalanced line output for message playback.

12. EXTERNAL TRIGGER PORT

Dry contacts to trigger the stored messages 1 to 16. Only voltage free contact is allowed to avoid damage.

13. DRY CONTACT

Dry contact is available whenever a message is activated. Can be used to interface with other devices such as volume controllers, zone selectors, etc.

14. XLR BALANCED OUTPUT

Balanced line output with XLR male connector.

Schematic Diagram

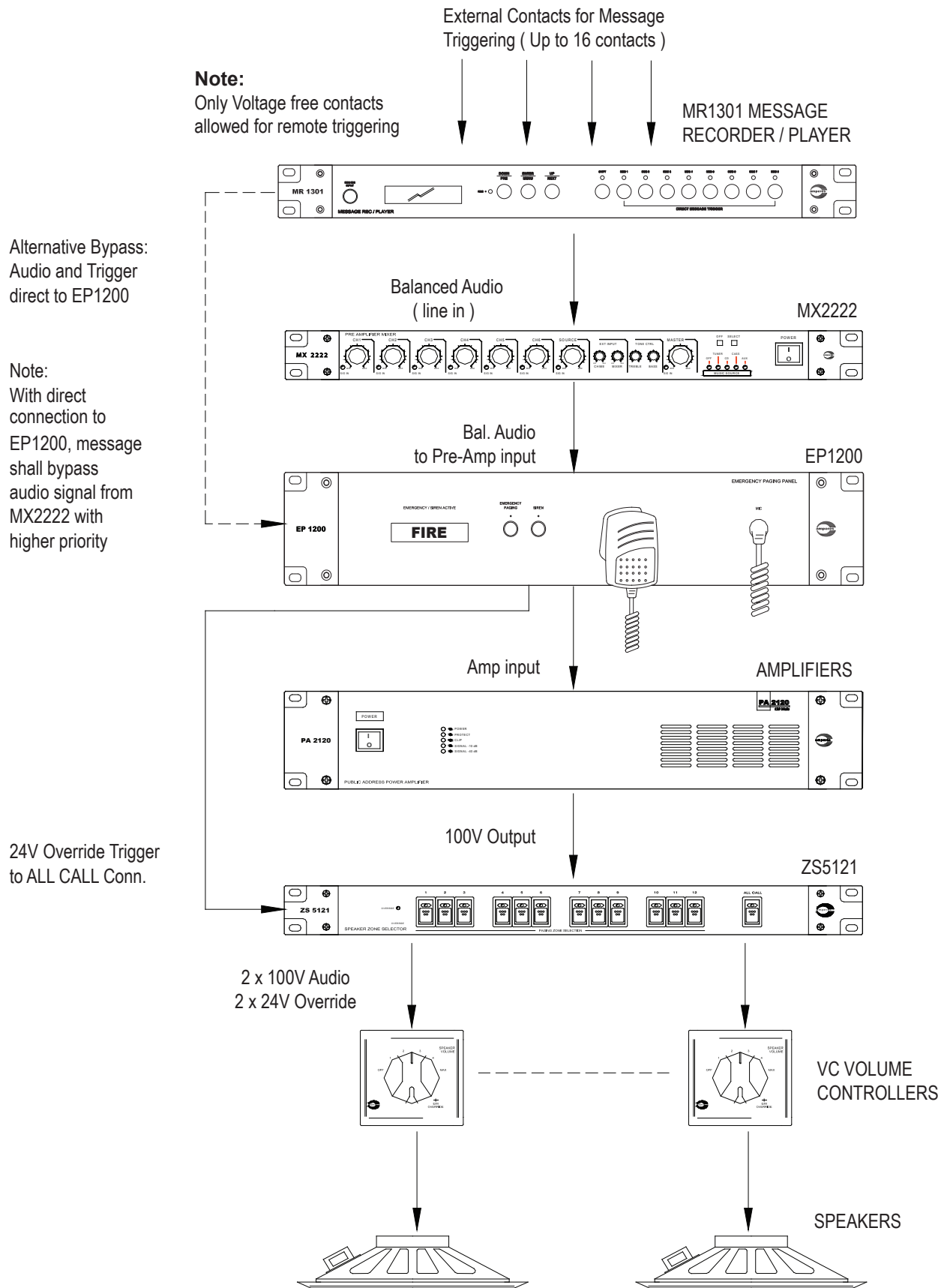

The above diagram shows typical schematic using MR1301 as message player, either for general repetitive message playback or for emergency voice evacuation purpose.

Connecting the Unit

MR1301 can be used as :

- Source playback unit, for delivering pre-recorded messages or songs, and if repetitive playback at certain times is required, it can be used together with a timer.
- Emergency broadcast message playback unit, which is linked to external triggering devices or systems, such as alarm, BAS or emergency push button.

Connections of both applications are shown in the diagrams below.

Option A : Using MR1301 for Normal Message Source

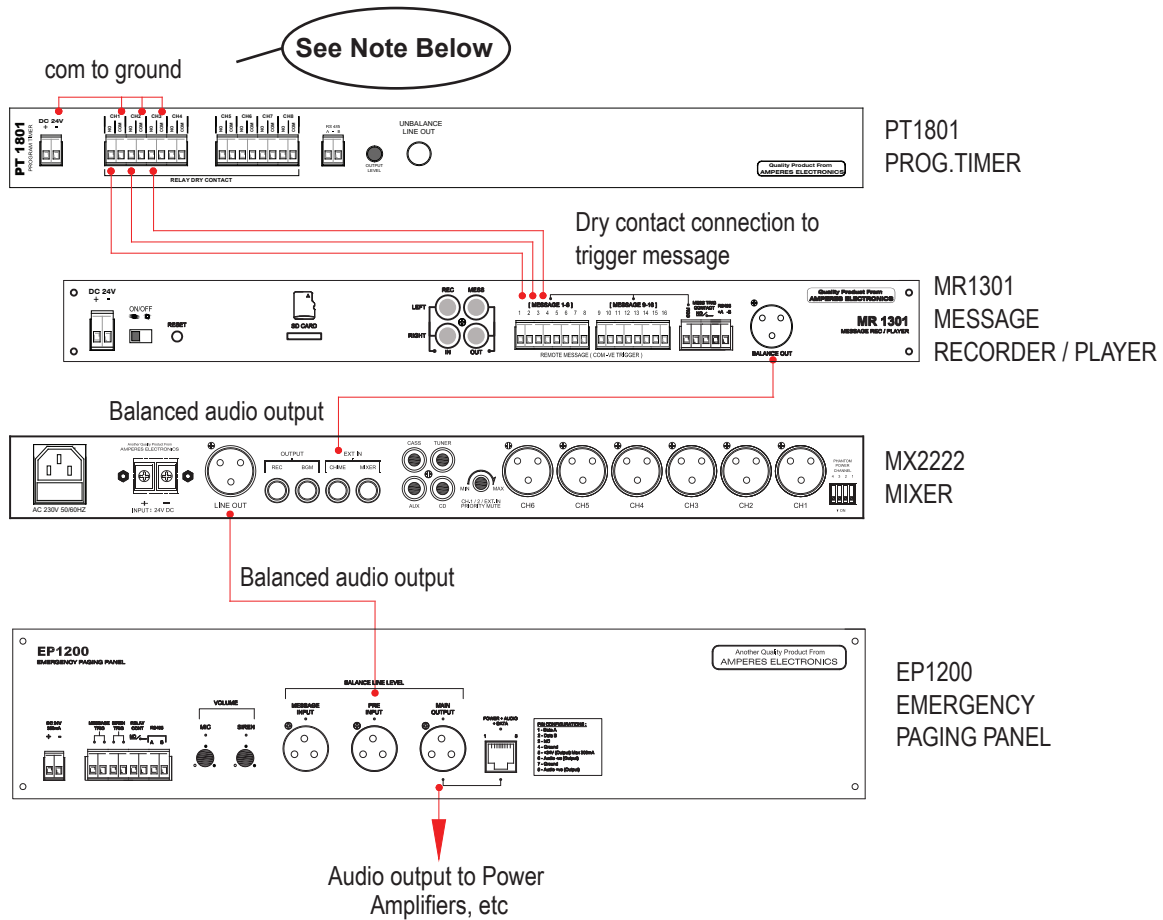

Stored messages can be played either from the front buttons or via the remote triggering ports.

The above diagram shows connections of 3 output channels of PT1801 connected to 3 individual triggering ports of MR1301. It is intended to perform 3 different times to playback 3 different messages. Activation of each message is via negative grounding.

Output from MR1301 can be unbalanced using RCA jack, or balanced signal using XLR jack. Both outputs are in mono mode, with line level signal.

Note :

Activation of a stored message can be either momentarily or pulse contact to ground. To activate from PT1801 timer, we recommend that the contact option at the channel output to be set to Pulse. A pulse shall not be more than 3 secs, otherwise it shall be regarded as a momentary latched contact.

Connecting the Unit

Option B : Using MR1301 for Emergency Announcement

MR1301 can be used as essential message source to PA system, linked to external activation device such as BAS system, emergency push button, etc.

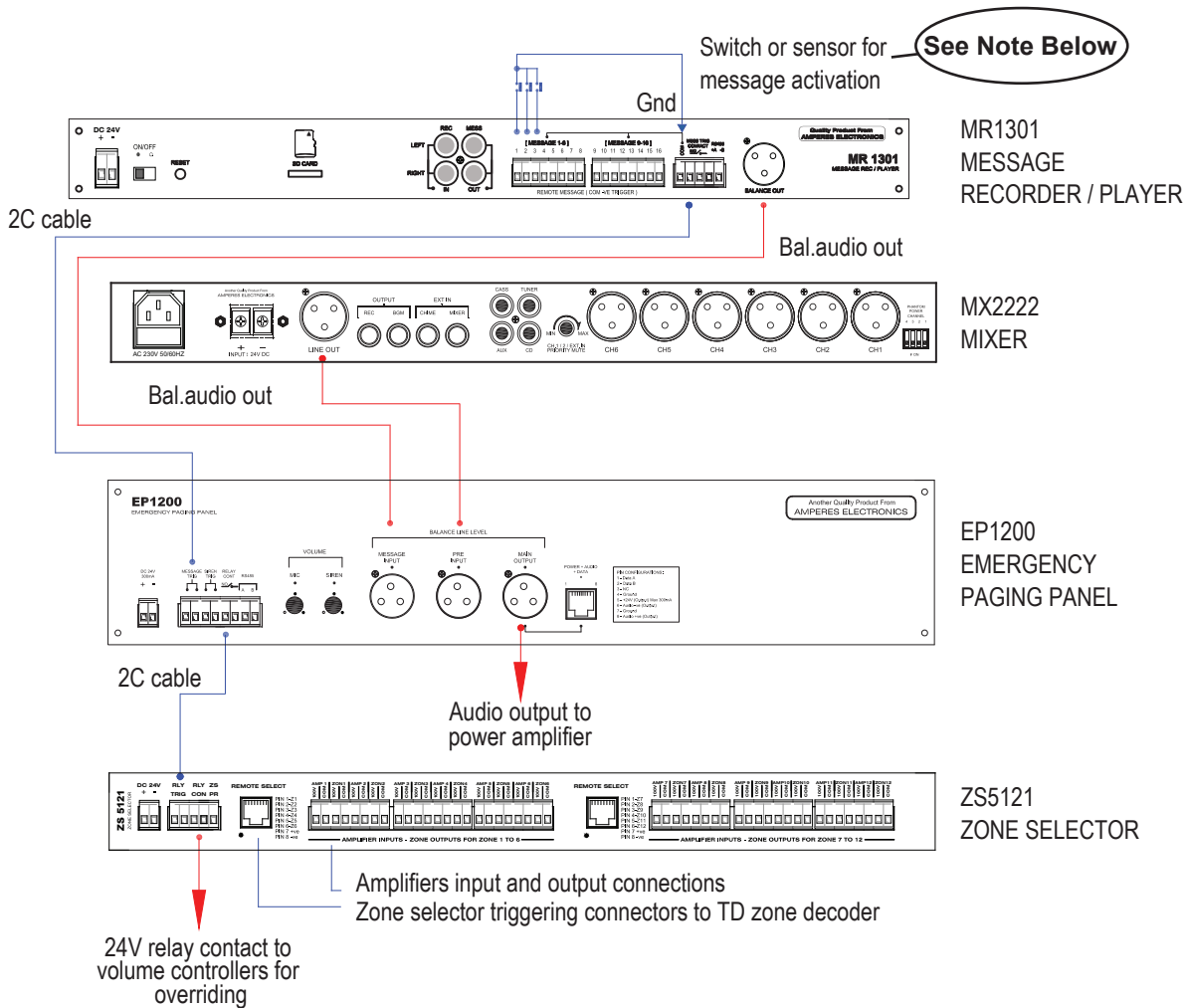

The dry contact at the MR1301 is used to trigger EP1200, thus overriding the normal audio source for priority paging. It is then connected to the Emergency Relay trigger at the Zone Selector, providing a dry contact for connecting 24V DC to override external volume controllers.

Note:

By default, the mode of activation is momentary. For this configuration, set it to momentary, and the dry contact shall be closed for the duration of the playback. This shall perform bypass of mixer audio output at EP1200 until the message is stopped.

Triggering Pre Recorded Message via UART (RS485)

MR1301 allows remote message activation via RS485 through the port available at the rear panel. To use this feature, please enquire from us for further technical details.

Connecting the Unit

Option C : Using BAS to control MR1301

In cases where Building Control System or BAS to be the domain controller including emergency voice announcement, it can be used to activate particular pre-recorded messages at MR1301.

The BAS would provide a close dry contact, which would activate mixer audio bypass at EP1200, as well as triggering a message at MR1301.

The typical connection diagram is illustrated below :

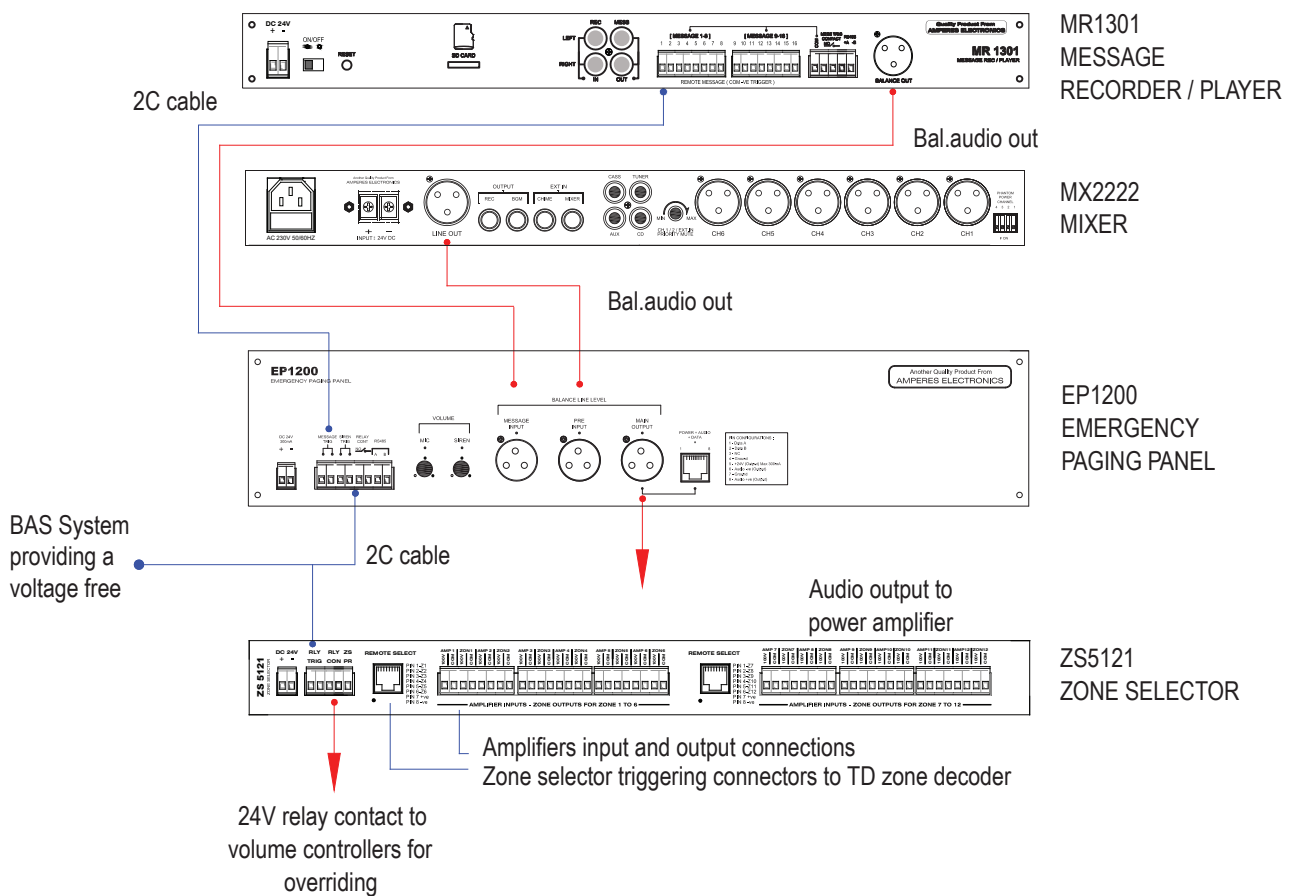

As EP1200 requires a latched contact to bypass the mixer output audio, BAS system should be able to provide a latched contact for the duration of the event.

Example, a fire sensor is activated and the BAS pick up the distress signal, it then provides a close contact, which is then required to mute normal BGM through EP1200. In the same time, activate a warning message via MR1301. The message shall be repeated until inspection is done and distress status is removed.

Setup Menu

Setting Up Via Front Panel Menu :

The Menu Flowchart :

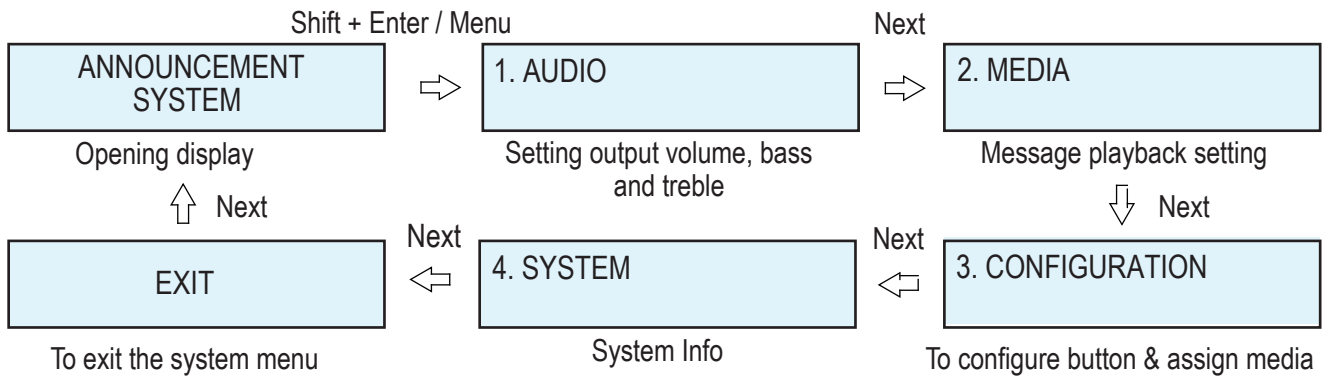

1. Audio

It is used to set the output volume, bass and treble of pre-recorded messages.

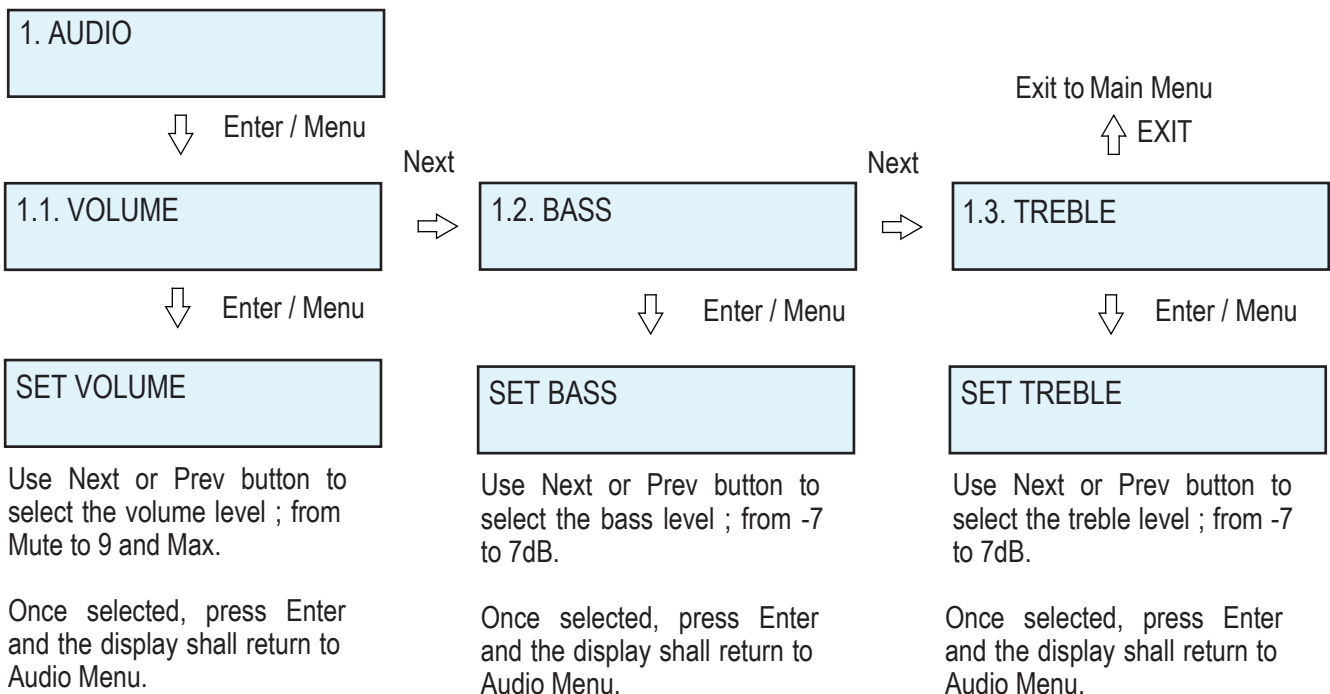

2. Media

To record live voice file and to play recorded media in the SD Card.

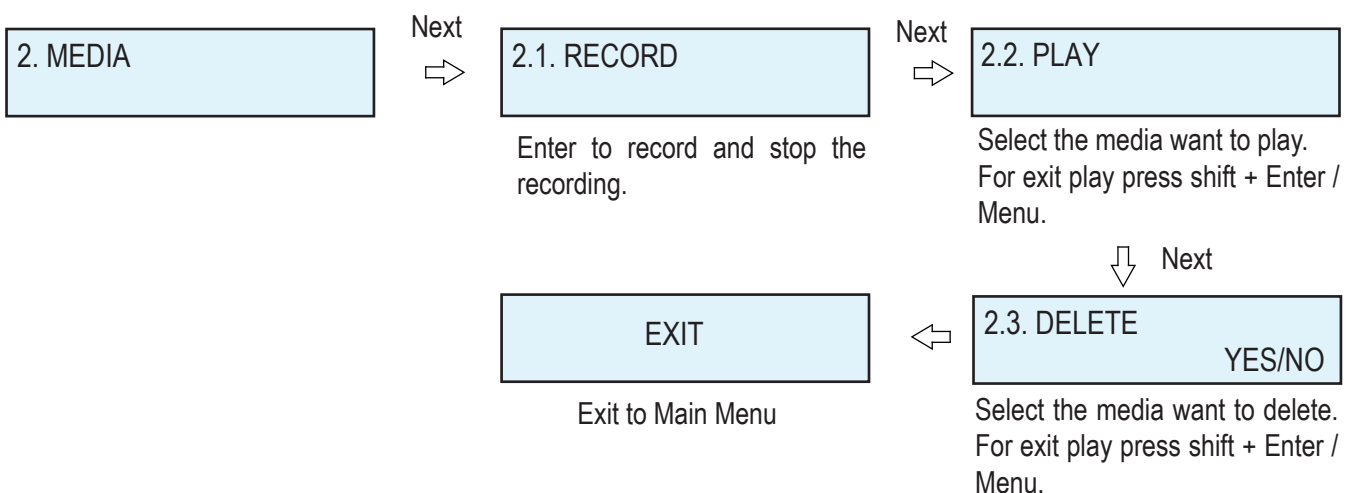

Setup Menu

3. Configuration

To configure a button, assigning media to respective buttons, inserting delay between messages & repeats of messages.

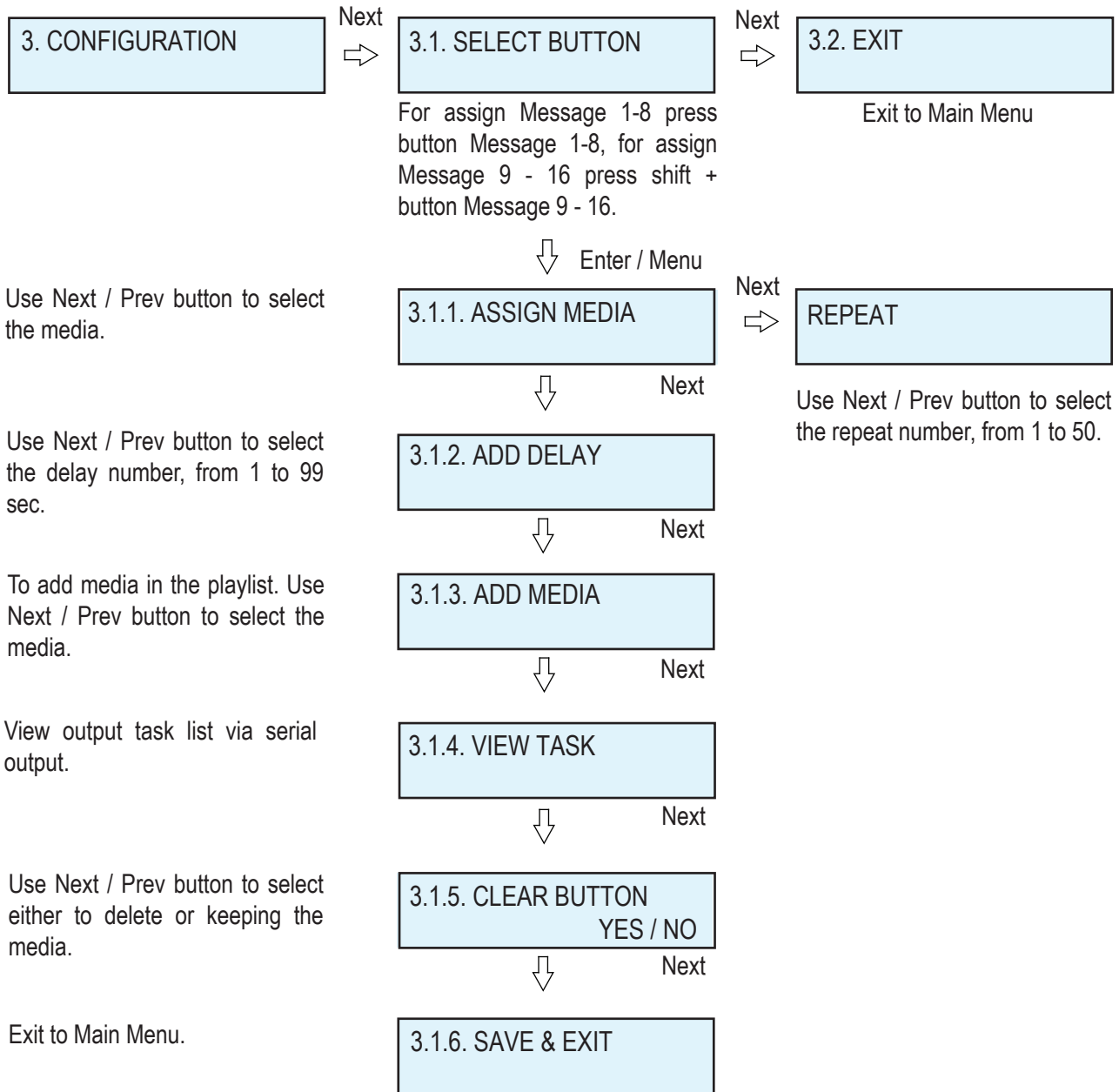

4. System

System Information.

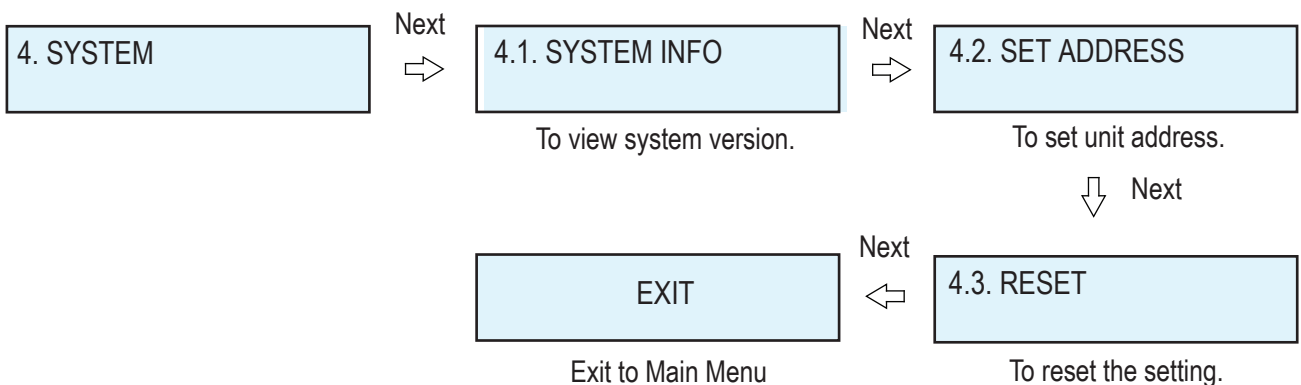

Setup Via PC

Follow the following steps in setup the button via PC :

Insert SD Card to PC



Open the SD Card and find 'MR1301 Configuration Folder'



Open application 'MR1301 SDCard Config'

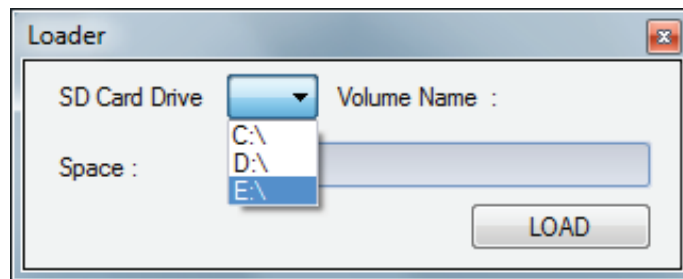

Select SD Card Drive before starting. After select press 'LOAD'



(1) Select message button

No.	TASKTYPE	TASKDETAIL	TASKM
0	MEDIA	CHIME_~2.MP3	0

(2) Select file to store in SD Card

(3) Add next file if required

(4) Repeat a playback

(5) Add a delay between to another

(6) Save the configuration

Setting the button 1-16 via this configurator. (Add Media, Repeat and Delay)



After completion of the settings, eject the SD Card and insert it to MR1301. The new configuration would automatically operational upon activation of the unit.

Recording a Voice File

To record live voice file and to play recorded media in the SD Card. Press “shift + Enter/ Menu” and go to MENU number “ 2. MEDIA ”.

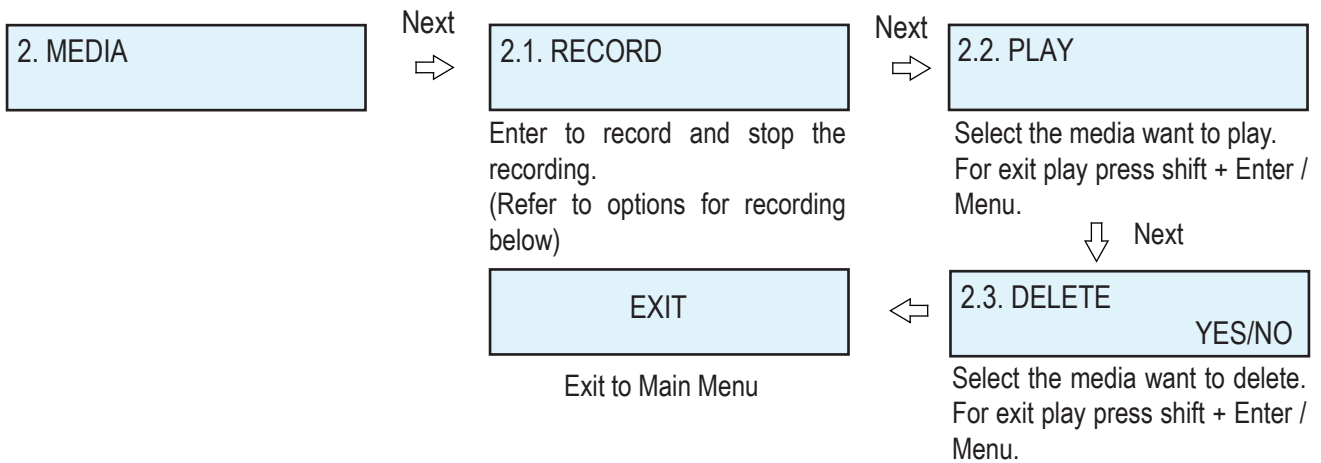

Recording a voice file can be done in two ways, being

1. Direct voice recording microphone / line input from music player and
2. Saving a voice file directly into SD card and the saved message shall be assigned with a unique message number.

Recording a Voice File

Option A : Direct voice recording

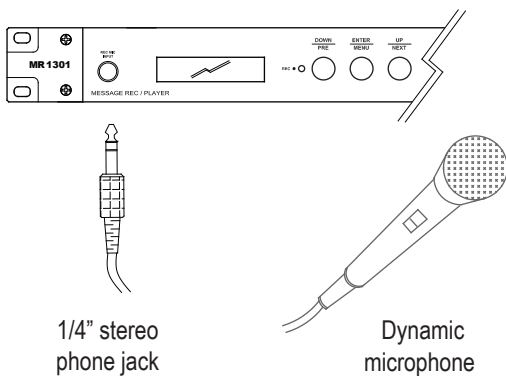

Recording using dynamic microphone through front panel phone jack.

Option B : Recording via external player

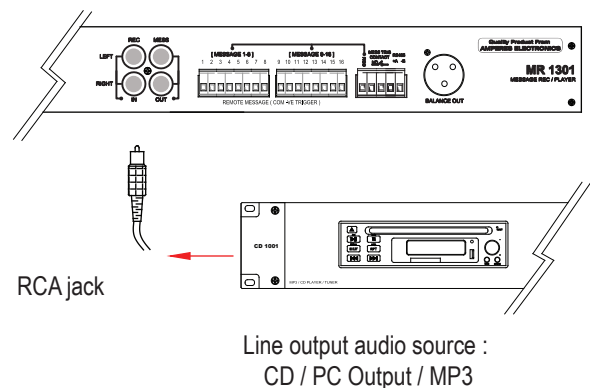

Recording using external line audio source with RCA jack at rear of the unit

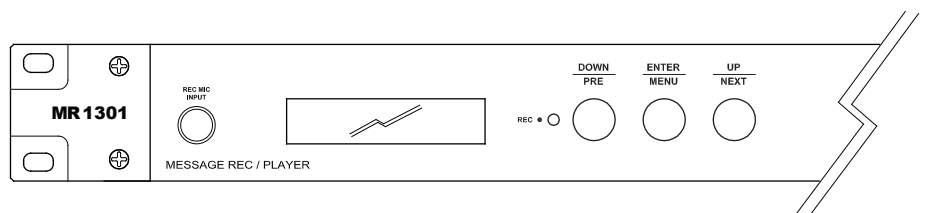

The direct recording of voice shall be saved into the SD card through PCM coding. The quality is best for voice and it is less favourable for music. To obtain a high quality music playback, we recommend using the direct file transfer method, which is explained in the next section.

The saved file can be renamed to easier message identification. Plug the USB Card into your PC and rename them with your own file name.

Saving Files Directly Into SD Card

MR1301 allows various format of files for playback, such as MP3, WMA and etc. Saving a high quality of audio format, such as MP3 would produce better sound output, especially for music files.

As currently MR1301 only perform PCM coding for direct recording, we recommend that music file to be directly stored into the SD card, in order to obtain a reasonable quality of audio output.

A few simple steps to save files into SD Card :

1. Insert a SD card provided into Card Reader which is connected to your PC via USB port.
2. From source window, drag the audio files to destination folder in the SD card.

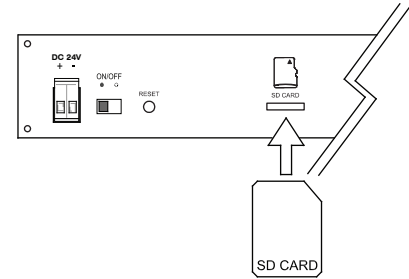

Slot for SD Card at the rear of the unit

Note :

1. The number of files (songs) that can be saved to a SD Card is subjected to the capacity of the storage space.
2. Typically, the following rules can be applied for MP3 format file:

<u>File size / minute</u>	<u>No. of files (16 GB SD Card)</u>	<u>Total messages length</u>
840 KB	19,900	19,900 min
44 MB	370	370 min
2.4 MB	6,820	6,820 min

3. Each memory bank can store multiple files, for case of message grouping under same nature of message broadcast. Example, greeting on opening of business, all languages of the greetings can be stored in one memory bank.

Message Playback

Stored voice file can be played by using the front direct switches (Message 1 to 16) or via the remote triggering ports.

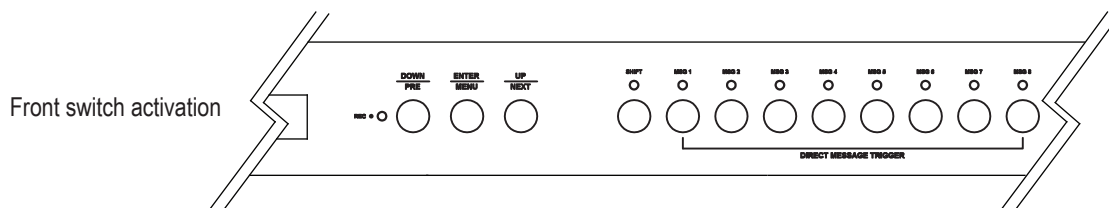

For message 9 to 16, press shift + the required button to trigger the message.

e.g: No 10, Press shift + message 2

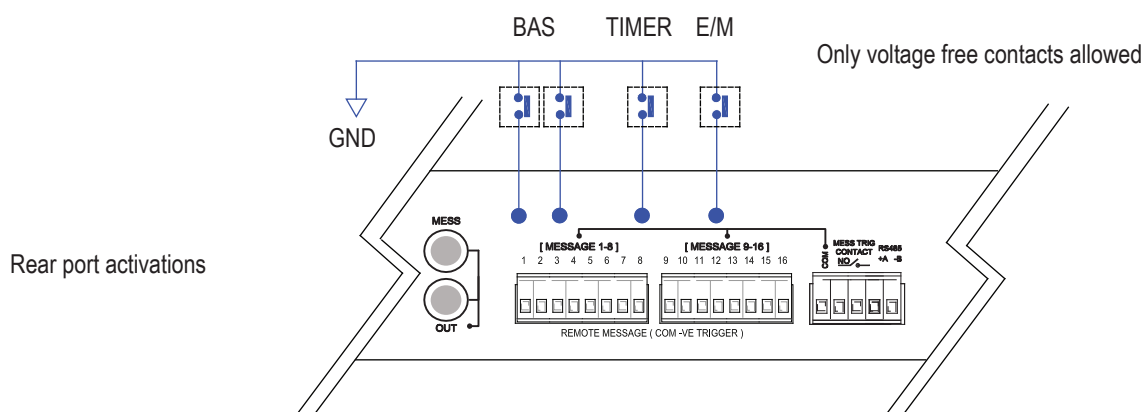
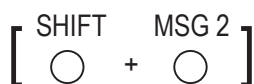

Activation via rear port can be from any external device or system providing a voltage free contact.

To activate a message, the relevant port shall be grounded and the type of activation can be either pulse contact or latch.

For pulse contact (momentarily), a close circuit will activate the message, and while the message is being played, another incoming pulse shall deactivate the announcement.

In cases where a latched contact is provided, the message will be played for as long as the closed contact remained as such.

The priority rule shall be the same for rear activation. Message 1 shall have highest priority.

Firmware Update Via SD Card

A prominent feature in this upgraded version is the Firmware upgrade method. Direct PC connection is not required and the whole process shall be done automatically. once a new firmware is detected in the SD Card upon power up.

Follow the following steps in firmware update:

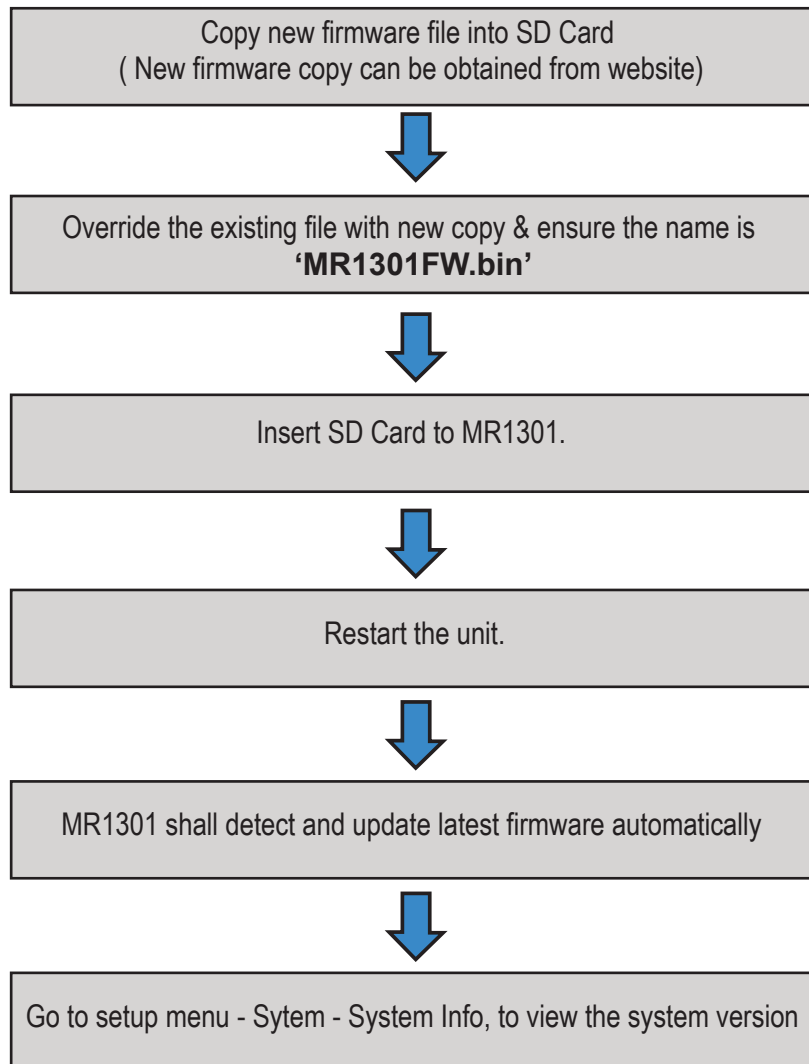

Summary of Features

- 32 bit ARM chip for faster and multitasking processing of data
- Up to 16GB of memory space using Micro SD card
- Message playback via front direct access button and rear remote triggering
- High quality MP3 playback of up to 320 kbps
- 128 kbps IMA ADPCM voice recording for better clarity
- Flexible message configuration in every memory bank eg. Multiple files in a single button
- Priority message playback with dry contact activation
- Playback controls ie. Volume, Repeat, Bass and Treble
- RS485 output with PC link for remote monitoring or using iPX5500 UART-IP converter for monitoring and control via LAN. (Application software : PMX II LAN)
- Auto firmware update / detection upon power up.

Technical Specifications

Operating Voltage	24V DC
Power Consumption	1W
Data Communication	RS485 at 19.2 kbps
Inputs	Line input: unbalanced via RCA jack Microphone input: Front phone jack
Processor	32 bit ARM
Message trigger	16 front and rear message
Playback format	MP3, WMA, WAV
Voice recording	IMA ADPCM 16 KHz Sampling Rate Bit Rate : 128 kbps (MP3)
Files in single bank	Up to 20 messages per button
Delay set up in playback	Yes
Priority message cut	Yes
Software interface	Yes
Remote view / control	Yes
Indicators	LED at switches, LCD display
Memory	MicroSD (up to 16 GB)
Dimension	482 x 44 x 130 mm
Weight	2 kg

Warranty Conditions

Only Amperes Electronics Service Centres are allowed to make warranty repairs : a list of Amperes Electronics Service Centres may be asked for by the purchaser or send directly to Amperes Electronics Sdn Bhd at 70 Jalan Industri PBP 3, Tmn Perindustrian Pusat Bandar Puchong, 47100, Puchong, Selangor, Malaysia or its authorized dealers. This warranty is not valid if repairs are performed by unauthorized personnel or service centres.

This warranty covers only repairs and replacement of defective parts ; cost and risks of transportation as well as removal and installation of the product from the main system are for the account of the purchaser. This warranty shall not extend to the replacement of the unit.

This warranty does not cover damages caused by misuse, neglect, accident of the product as well as using the product with power supply voltage other than shown on the product, or any other power supply source / adaptor not recommended by the manufacturer.

This warranty does not cover damages caused by fire, earthquakes, floods, lightning and every cause not directly related to the unit.

This warranty does not include any indemnity in favor of the purchaser or the dealer for the period out of use of the unit; moreover the warranty does not cover any damages which may be caused to people and things when using the product.

This warranty certificate is valid only for the described product, and is not valid if modifications are made on this certificate or on the identification label applied on the product.

This warranty covers all the material and manufacturing defects and is valid for a period of 36 months from the date of purchase or for a specified period in countries where this is stated by a national law. In this case, the extension is valid only in the country where the product is purchased.

Amperes Electronics Sdn Bhd is not obliged to modify previously manufactured products under warranty if the design changes or improvements are made.

Disclaimer

Information contained in this manual is subject to change without prior notice and does not represent a commitment on the part of the vendor. AMPERES ELECTRONICS SDN BHD shall not be liable for any loss or damages whatsoever arising from the use of information or any error contained in this manual.

It is recommended that all services and repairs on this product be carried out by AMPERES ELECTRONICS SDN BHD or its authorized service agents.

AMPERES series must only be used for the purpose they were intended by the manufacturer and in conjunction with this operating manual.

AMPERES ELECTRONICS SDN BHD cannot accept any liability whatsoever for any loss or damages caused by service, maintenance or repair by unauthorized personnel, or by use other than that intended by the manufacturer.



ISO 9001: 2015
Design & Manufacture of Public Address Equipment and Systems
Certificate No. 16895 / A / 0001 / UK / En



AMPERES ELECTRONICS SDN BHD
MADE IN MALAYSIA
Published : SEPTEMBER 2020