

SAMPLE SCHEMATIC : DRAWING REFERENCE : pa-conv-digital 3

SAMPLE SCHEMATIC FOR HOTEL / MIXED DEVELOPMENT AND SIMILAR APPLICATIONS (ILLUSTRATIONS FOR OUTPUT SECTIONS)

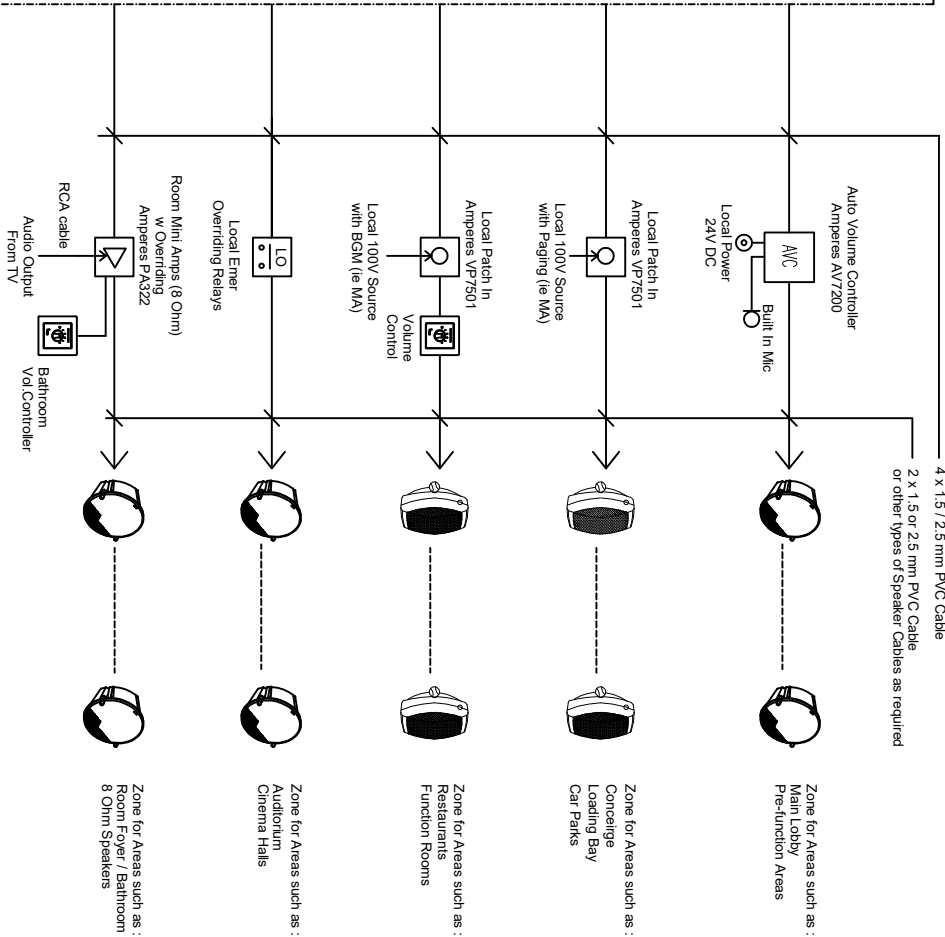
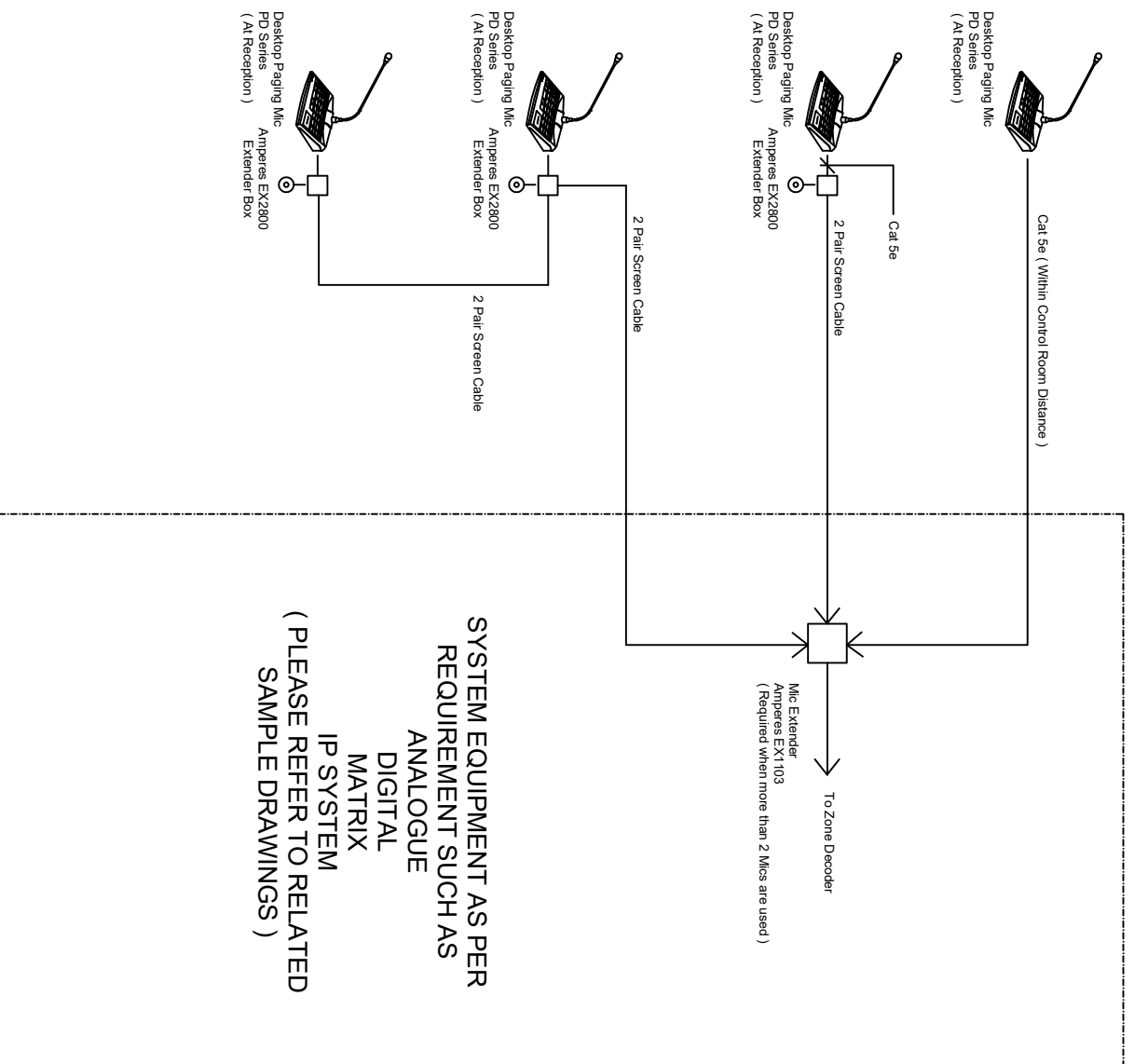

Paging mics shown are possible requirements with different cabling versions according to distance
Speaker types can be selected as per requirement or preference.
Larger scale / signature hotels may have different configurations
Ⓢ Indicates local power source is required

Disclaimer :
The above is an illustration of possible configuration for this category. Amperes is not liable for any claim or whatsoever for errors in installation.
For specific applications, please contact our technical team for further advice.